



Corrugated Metal Gaskets for Superior Reliability

Graphonic® Series of Gaskets

Technical Manual

GET™, Graphonic®, and Tephonic™ Gaskets

Garlock

SEALING TECHNOLOGIES®



Garlock Sealing Technologies

A century of excellence in fluid sealing technology



The success of nearly every manufacturing and process facility in the world depends on the reliable operation of countless pumps, valves, motors and piping systems.



Those vital pieces of equipment operate longer and more efficiently when running with Garlock Sealing Technologies gaskets, packings, hydraulic components, mechanical seals, oil seals, bearing protectors, and expansion joints.



For more than a century, Garlock Sealing Technologies has designed, tested and manufactured the most innovative and high quality fluid sealing products available. As a result, industrial customers around the globe have come to rely on Garlock products as a key to their profitability and success.



Garlock Metallic Gaskets, a division of Garlock Sealing Technologies, manufactures spiral wound, metal clad, and solid metal gaskets at its facility in Houston, Texas. This facility is registered to ISO-9002.



In recent years, Garlock Metallic Gaskets has introduced some of the industry's most innovative production methods and products. For example, CONTROLLED DENSITY® winding for spiral wound gaskets provides a high tightness level with reduced gasket stress. The TANDEM SEAL™ combines chemical resistance and fire safety in a single gasket, while the Garlock EDGE® gasket eliminates the costly and potentially catastrophic problem of radial buckling.



Joining this innovative family at the Metallic Gasket Division are the Garlock GRAPHONIC® Series of Gaskets. This series of gaskets provides a full range of performance, designed to seal in the most severe



and the most common applications. The GET™, GRAPHONIC® and TEPHONIC™ gaskets will save money and increase margins of safety. The new emission laws and the need to make your plant run as efficiently as possible, make the GRAPHONIC® Series of Gaskets The **RIGHT GASKET** for your applications.

Corrugated gasket metal technology has been a proven provider of sealing solutions for tough applications. The GET™, GRAPHONIC® and TEPHONIC™ gaskets have a successful track record, showing cost reductions through improved heat exchanger reliability and overall increased equipment productivity.

This unique construction, utilizing corrugated metal and compressible sealing elements, provides for excellent performance in thermal cycling applications. This configuration provides a rigid gasket that easily seals against flange seating surface imperfections.

The GET™, GRAPHONIC® and TEPHONIC™ gaskets handle a wide variety of applications. This premium gasket has passed various industry standard fire tests (API 607 4th ed. modified; FITT) and is suitable for 150# and 300# ANSI sized piping and vessel applications.

This catalog is provided for customer information and convenience. However, Garlock Metallic Gaskets applications engineers and customer service personnel are also on hand to assist you with your application requirements and technical questions. Please give us a call at 800-972-7638. We're here to serve you.

CONTROLLED DENSITY, EDGE, GRAPHONIC, FLEXSEAL are registered trademarks of Garlock Inc.

TEPHONIC, TANDEM SEAL, STABL-LOCK and GET are trademarks of Garlock Inc.

Contents

Introduction	2
GET™ Gasket	3
GRAPHONIC® Gasket	4
TEPHONIC™ Gasket	5
Selection of Metals	6
Chemical Resistance of Flexible Graphite and ePTFE	7
Flange Rotation	8
Definition of Gasket Stress	9
Effective Gasket Seating Width	10
Gasket Factors “M” and “Y”	11
Test Results - Overview	
ROTT Test	12, 13
Gasket Constants – Crush Test	14
Gasket Leak Rate T3 vs Gasket Stress	15
Gasket Stress vs Mass Leakage	15
Mass Leak Rate to Volumetric Leak Rate	16
Fire Integrity	17
Performance Comparison Load Charts	18
Performance Comparison Unload Charts	19
Gasket Constants	20
Glossary of Terms	21-25
Appendix	
PVRC Method	26-29
PVRC Method Notations	30, 31
PVRC Flow Chart	32
Gasket Dimensions for Standard Flanges	33
Heat Exchanger Gaskets	34
Heat Exchanger Gasket Shapes	35
Bolt Torque Tables	36
Application Data Form	37

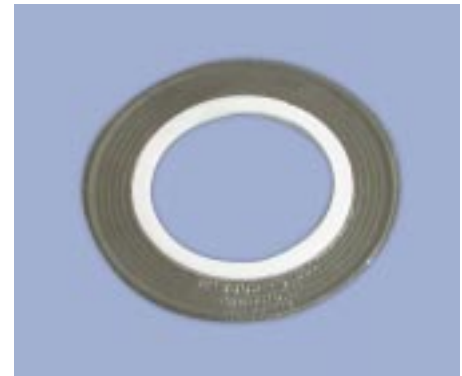

Introduction

The selection of gaskets has become more critical because of a number of factors:

- Pipes and joints are now included in the pressure vessel codes
- Tighter rules for emission control
- Aggressive effort to lower costs by reducing product loss and increasing margins of safety
- The international demand for standards for evaluating asbestos-free gaskets

Because of the tighter standards of emission control and restrictions on the use of gaskets containing asbestos, Garlock is committed to continuous development of better sealing systems for bolted gasket flanges. Our impressive new GRAPHONIC® Series of Gaskets provides superior performance over other gaskets.

Standard Flange

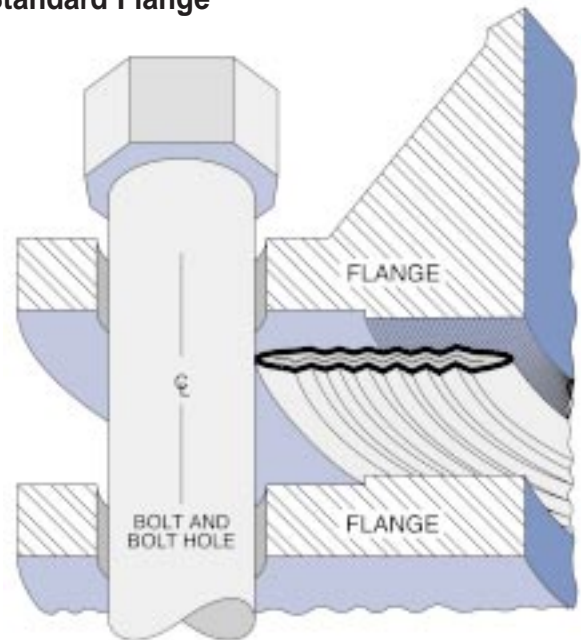

GRAPHONIC® Series Advantages

The GRAPHONIC® Series of Gaskets saves money and increases margins of safety by:

- Better resistance against both chemical attack and high temperatures
- Reducing product loss through leakage in pipe and heat exchanger flanges
- Eliminating monitoring due to excessive fugitive emission levels
- Fewer industrial accidents caused by sudden gasket failure
- Preventing costs associated with production loss through plant shutdown and environmental clean-up costs

Heat Exchanger

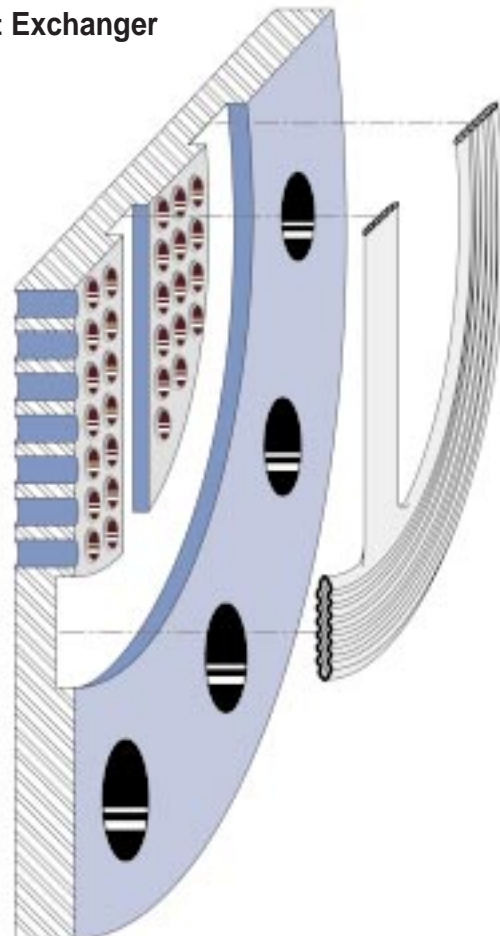

*Patent numbers 5,421,594 and 6,092,811

WARNING:

Properties/applications shown throughout this brochure are typical. Your specific application should not be undertaken without independent study and evaluation for suitability. For specific application recommendations consult Garlock. Failure to select the proper sealing products could result in property damage and/or serious personal injury. Performance data published in this brochure has been developed from field testing, customer field reports and/or in-house testing.

While the utmost care has been used in compiling this brochure, we assume no responsibility for errors. Specifications subject to change without notice. This edition cancels all previous issues. Subject to change without notice.

GET™ Gasket

Advantages

Graphite and ePTFE Combination

- Chemical resistance and fire safety simultaneously
- The tightest seal of the GRAPHONIC® Series of Gaskets (under 500°F/260°C).

Corrugated Metal Core

- Minimizes extrusions
- Redirects compressible sealing element and blocks leak paths
- Adds strength and rigidity
- Increases sealability under low bolt loads
- Actively assists in thermal cycling applications

Benefits

- Can be used in a wide variety of applications
- Is forgiving on worn and corroded flange surfaces
- Passed fire tests, API 607, 4 ed., modified and FITT's tests
- Seals under a wide range of loads

Specifications

Material:	Corrugated metal encapsulated with bonded flexible graphite and ePTFE
Nominal thickness:	1/8" (3.2 mm)
Graphite layers:	2 layers, each flexible graphite
ePTFE ID seal:	Expanded Teflon® envelope on ID of gasket
Metal inset:	Nominal thickness 0.024" (0.6 mm) austenitic stainless steel with corrugations (Other types of metal are available)
Gasket dimensions:	Per ASME B 16.21
Continuous operating temperature:	
Minimum:	-350°F (-210°C)
Max. in steam:	600°F (314°C)
Pressure, max.:	2000 psig (140 bar)
P x T, max.:	
1/8" thickness:	300,000 (10,250)†

Note: When approaching maximum temperatures, consult the Garlock Metallic Gasket Engineering Dept. at 1-800-972-7638 or 1-281-459-7200.

† P x T max. = psig x °F (bar x °C)

Teflon is a registered trademark of DuPont.

Construction

With or without metal rings

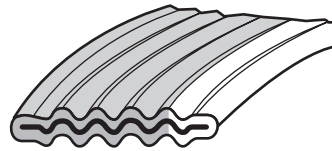

Figure 1:
GET™ Gasket
without Metal
Rings

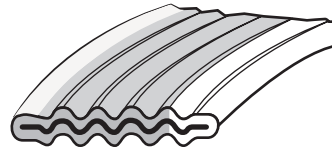

Figure 2:
GET™ Gasket
with Outer Metal
Ring

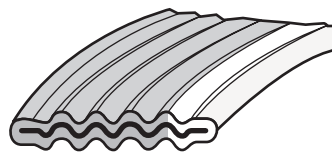

Figure 3:
GET™ Gasket
with Inner Metal
Ring

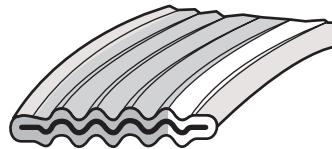
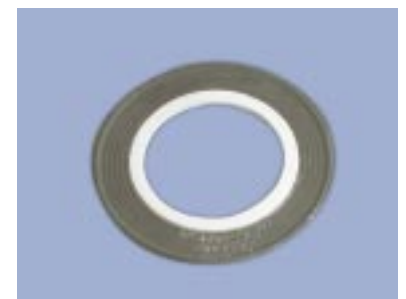

Figure 4:
GET™ Gasket
with Outer and
Inner Metal Rings



GRAPHONIC[®] Gasket

Advantages

Flexible Graphite

- Accommodates a wide range of temperatures
- Inherently resilient
- Chemically resistant
- Excellent aging characteristics
- Is forgiving on pitted or corroded flange surfaces

Corrugated Metal Core

- Minimizes extrusions
- Redirects compressible sealing element into the leak paths
- Adds strength and rigidity
- Increases sealability under low bolt loads
- Actively assist in thermal cycling applications

Benefits

- Can be used in a wide variety of applications
- Excels in thermal cycling conditions
- Increases heat exchanger reliability
- Passes fire tests, API and FITTs tests
- Is forgiving on worn and corroded flange surfaces
- Seals under a wide range of loads

Construction

With or without metal rings

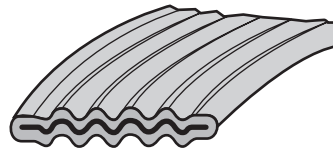

Figure 1:
GRAPHONIC[®]
Gasket without
Metal Rings

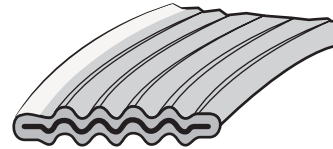

Figure 2:
GRAPHONIC[®]
Gasket with Outer
Metal Ring

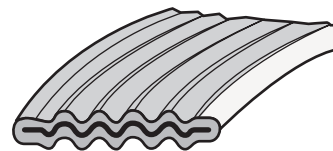

Figure 3:
GRAPHONIC[®]
Gasket with Inner
Metal Ring

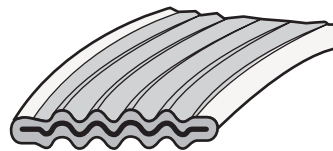

Figure 4:
GRAPHONIC[®]
Gasket with Outer
and Inner Metal
Rings

Specifications

Material:	Corrugated metal encapsulated with bonded flexible graphite
Nominal thickness:	1/16" (1.6 mm) and 1/8" (3.2 mm)
Graphite layers:	2 layers, each flexible graphite
Metal inset:	Nominal thickness 0.024" (0.6 mm) austenitic stainless steel with corrugations (Other types of metal are available)
Gasket dimensions:	Per ASME B 16.21
Continuous operating temperature:	
Minimum:	-400°F (-240°C)
Max. in steam:	1200°F (650°C)
Pressure, max.:	2000 psig (140 bar)
P x T, max.:	
1/16" thickness:	700,000 (25,000) [†]
1/8" thickness:	400,000 (13,500) [†]



* Maximum temperatures of 975°F (525°C) can be allowed for flexible graphite with oxidation inhibitors.

[†] P x T max. = psig x °F (bar x °C)

Note: When approaching maximum temperatures, consult the Garlock Metallic Gasket Engineering Dept. at 1-800-972-7638 or 1-281-459-7200.

TEPHONIC™ Gasket

Advantages

ePTFE Compressible Sealing Element

- Chemically inert
- Creates an extremely tight seal
- A soft and deformable seal

Corrugated Metal Core

- Minimizes extrusions
- Redirects compressible sealing element and blocks leak paths
- Adds strength and rigidity
- Increases sealability under low bolt loads
- Actively assist in thermal cycling applications

Benefits

- Offers superior chemical resistance (with compatible metal core)
- Capable of sealing with low bolt loads
- Can be used in a wide variety of applications
- Is forgiving on worn and corroded flange surfaces

Specifications

Material:	Corrugated metal encapsulated with bonded ePTFE
Nominal thickness:	1/8" (3.2 mm)
ePTFE:	2 layers, each ePTFE
Metal inset:	Nominal thickness 0.024" (0.6 mm) austenitic stainless steel with corrugations (Other types of metal are available)
Gasket dimensions:	Per ASME B 16.21
Continuous operating temperature:	
Minimum:	-350°F (-210°C)
Max. in steam:	500°F (260°C)
Pressure, max.:	2000 psig (140 bar)
P x T, max.	
1/8" thickness:	250,000 (8,500) [†]

[†] P x T max. = psig x °F (bar x °C)

Note: When approaching maximum temperatures, consult the Garlock Metallic Gasket Engineering Dept. at 1-800-972-7638 or 1-281-459-7200.

Construction

With or without metal rings

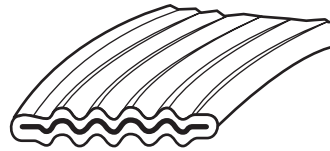

Figure 1:
TEPHONIC™
Gasket without
Metal Rings

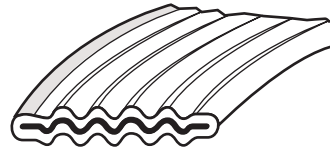

Figure 2:
TEPHONIC™
Gasket with Outer
Metal Ring

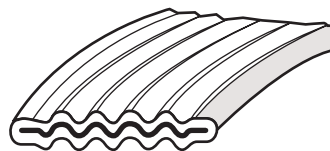

Figure 3:
TEPHONIC™
Gasket with Inner
Metal Ring

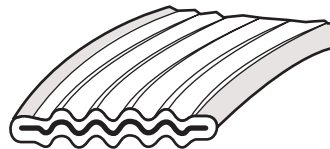

Figure 4:
TEPHONIC™
Gasket with Outer
and Inner Metal
Rings



WARNING:

Properties/applications shown throughout this brochure are typical. Your specific application should not be undertaken without independent study and evaluation for suitability. For specific application recommendations consult Garlock. Failure to select the proper sealing products could result in property damage and/or serious personal injury.

Performance data published in this brochure has been developed from field testing, customer field reports and/or in-house testing. While the utmost care has been used in compiling this brochure, we assume no responsibility for errors. Specifications subject to change without notice. This edition cancels all previous issues. Subject to change without notice.

Selection of Metals

The chemical resistance for the GRAPHONIC® Series of Gaskets will be governed by their materials of construction.

The metal core of the GRAPHONIC® Series of Gaskets can be selected from most types of sheet metal. The selection is generally based on chemical resistance, heat resistance and cost. The most popular metals for the GRAPHONIC® Series of Gaskets include:

- Mild steel
- HASTELLOY C®276†
- Stainless steel 304
- MONEL® 400‡
- Stainless steel 316
- INCONEL® 625*
- INCONEL® 600*
- INCOLOY® 825*
- Nickel 200

The selection of a metal to be used in a gasket that is suitably resistant to corrosive media or to high temperature involves many considerations. Garlock recommends that designers contact the manufacturers of alloyed material, who conduct laboratory corrosive tests and in-plant corrosion testing.

Concentration of Corrosive Agents

Dilute solutions are not necessarily less corrosive than those of full strength, and the reverse is often the case. Probably the most familiar example of this is the action of sulfuric acid on iron; concentrations over 90% acid may be handled by iron without much difficulty, but below this concentration, the rate of attack will increase rapidly with an increase in dilution.

Purity of Corrosive Agents

Purity, in this instance, means the absence of contaminating amounts of other corrosive compounds. For example, the corrosive attack by compounds that are derivatives of an acid: in the pure state these compounds may be relatively inert, but if contaminated by any

carry-over of free acid they must be handled more carefully.

Temperature

Besides its effects upon the mechanical properties of the gasket, the temperature of the corrosive agent will have a marked influence upon the rate of attack.

Forms of Corrosion

- General corrosion
- Galvanic corrosion
- Concentration cell or crevice corrosion
- Chemical pitting
- Intergranular corrosion
- Effects of stress on corrosion
 - Corrosion fatigue
 - Stress corrosion cracking

Corrosive Environments

- Atmospheric corrosion
- Corrosion by water, acids
- Corrosion by alkalis, salts, fluorine
- Corrosion by chlorines and hydrogen
- Corrosion by chlorides

* INCONEL® and INCOLOY® are registered trademarks of Inco Alloys International, Inc.

† HASTELLOY C® is a registered trademark of Haynes International.

‡ MONEL® is a registered trademark of International Nickel.

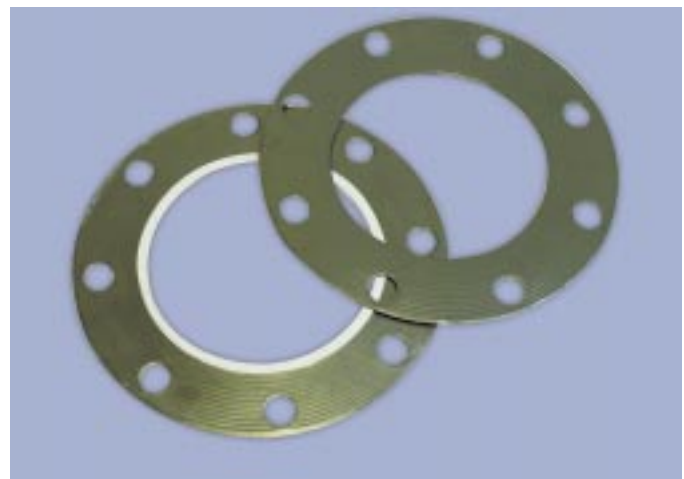

Chemical Resistance of Flexible Graphite and ePTFE

Completely Resistant ■

Moderately Resistant ▲

Not Resistant ▼

	Graphite	ePTFE		Graphite	ePTFE		Graphite	ePTFE
Acetic acid	■	■	Ethylene glycol	■	■	Potash (molten)	■	■
Acetone	■	■	Formaldehyde	■	■	Potassium (< 350°C) (molten)	■	▼
Acrylic acid ethyl ester	■	■	Fluorine (> 150°C)	▲	▲	Potassium chlorate (molten)	▼	▼
Air (< 550°C)	■	▼	Freon®	■	■	Potassium hydrogen sulfate (molten)	■	▼
Aluminum (molten)	■	▼	Gasoline	■	■	Potassium hydroxide solution (< 400°C)	■	▼
Ammonia	■	■	Heat transfer oil	■	■	Potassium nitrate (molten)	▼	▼
Ammonium hydroxide solution	■	■	Hydrochloric acid	■	■	Propane	■	■
Aqua regia	▼	■	Hydrofluoric acid	■	■	Silicones	■	■
Boric acid	■	■	Hydrofluoric (> 60% at room temperature)	▲	▲	Silver (molten)	■	▼
Bromine (dry)	▼	■	Hydrogen chloride	■	■	Soda (molten)	■	▼
Bromine (room temperature)	▲	▲	Hydrogen fluoride	■	■	Sodium (< 350°C) (molten)	■	▼
Calcium chloride (molten)	■	▼	Hydrogen peroxide (< 85%)	▼	■	Sodium hydroxide solution (< 400°C)	■	▼
Carbon dioxide (< 510°C)	■	▼	Iodine (room temperature)	■	■	Sodium peroxide (molten)	▼	▼
Carbon monoxide	■	■	Iron (molten)	▼	▼	Steam (< 750°C)	■	▼
Carbon tetrachloride	■	■	Isopropyl alcohol	■	■	Stearic acid	■	■
Chlorides (aqueous)	■	■	Methanol	■	■	Sulfur	■	■
Chlorine (dry)	■	■	Methyl ethyl ketone	■	■	Sulfur dioxide	■	■
Chlorine dioxide	▼	■	Motor oils	■	■	Sulfuric acid (93-96% at room temperature)	▼	▲
Chloroform	■	■	Nitrates (aqueous)	■	■	Sulfuric acid (70%-100%, up to 100°C)	▼	■
Chromates (< 20%) (aqueous)	■	■	Nitric acid (< 20%)	■	■	Sulfuric acid (> 96%, over 100°C)	▼	■
Chromic acid (< 10%, < 95°C)	■	■	Nitric acid	▼	■	Sulfur trioxide	▼	■
Citric acid	■	■	Nitric acid (> 20% at room temperature)	▲	▲	Zinc (molten)	■	▼
Copper (molten)	■	▼	Nitrobenzene	■	■			
Diethyl ether	■	■	Oleum (fuming sulfuric acid)	▼	■			
Dimethyl sulfoxide	■	■	Oxygen (260°C)	■	■			
Dioxane	■	■	Phenol	■	■			
Ethanol	■	■	Phosphates (aqueous)	■	■			
Ethanolamine	■	■	Phosphoric acid	■	■			
Ethylene	■	■						
Ethylene dichloride	■	■						

WARNING:

Properties/applications shown throughout this brochure are typical. Your specific application should not be undertaken without independent study and evaluation for suitability. For specific application recommendations consult Garlock. Failure to select the proper sealing products could result in property damage and/or serious personal injury. Performance data published in this brochure has been developed from field testing, customer field reports and/or in-house testing.

While the utmost care has been used in compiling this brochure, we assume no responsibility for errors. Specifications subject to change without notice. This edition cancels all previous issues. Subject to change without notice.

Flange Rotation

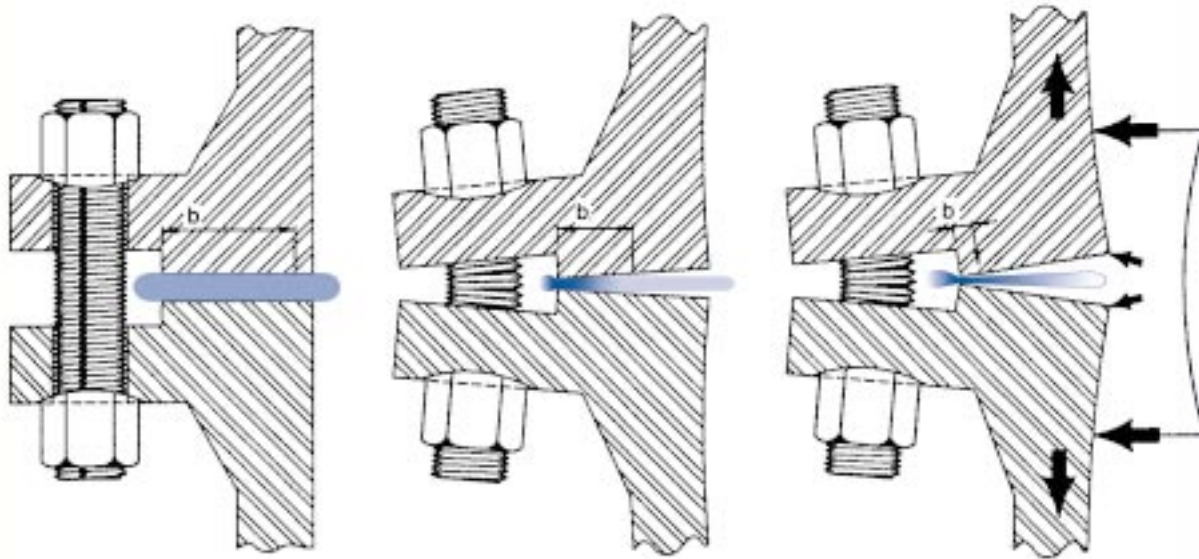

What is Flange Rotation?

A common problem in the pressure vessel and piping world is the phenomenon called flange rotation. It is usually encountered under bolt tightening with a raised face flange. The outer edges of a raised face flange are pulled towards each other when the bolts are tightened, and relieved towards the inside of the vessel or pipe. See illustration.

How Much Flange Rotation?

Petrochemical engineers who must cope with rotation say that it can greatly increase the difficulties of sealing a joint. Some even say that rotations as small as 0.10 degrees can make a tight seal almost impossible. This is quite a bit stiffer than the preliminary proposed ASME limit of a maximum 0.30 degrees for integral type flanges or 0.20 degrees for loose type flanges.

Flange Rotation and the Code

Flange rotation is known to be important but there are no simple ways to estimate it. Section VIII of the ASME Code, Table UA-49.2 Effective Gasket Width acknowledges rotation by introducing an effective width for a gasket, which is equal to or less than half the width of the gasket or joint-contact-surface seating width. This allowance leakage assumes that at least half of the gasket will have been

unloaded by rotation. But flanges often rotate more or less than this. Proper installation and bolt tightening procedures greatly reduce the chance for flange rotation.

Excessive Bolt Load

One of the causes of flange rotation is excessive bolt load. In fact, too much bolt load can rotate raised face flanges enough to open a leak path. The threat of rotation, therefore, can place an upper limit on planned or specific clamping force.

WARNING:

Properties/applications shown throughout this brochure are typical. Your specific application should not be undertaken without independent study and evaluation for suitability. For specific application recommendations consult Garlock. Failure to select the proper sealing products could result in property damage and/or serious personal injury. Performance data published in this brochure has been developed from field testing, customer field reports and/or in-house testing. While the utmost care has been used in compiling this brochure, we assume no responsibility for errors. Specifications subject to change without notice. This edition cancels all previous issues. Subject to change without notice.

Definition of Gasket Stress

Gasket stress is the contact pressure between the flange and gasket bearing surface. The definition of stress is the magnitude of the force applied to the area of the gasket on which the force acts. In a flange it is created by the applied force from the tension in the bolts clamping the flanges.

Gasket Contact Area Symbols and Units

- Go = The smaller of Gasket OD or flange sealing surface OD (inch)
- OD = Outside diameter of sealing surface, gasket or flange face (inch)
- ID = Inside diameter of sealing surface, gasket (inch)
- N = Width of full gasket contact sealing used to determine the basic gasket seating width (inch)
- Ag = Full gasket contact area based on the contact width (in²)

For initial seating, use the full contact area of the gasket. When the joint is pressurized, the PVRC introduces an effective (roughly half) width (N) that is the same as (b) in the ASME Code, Section VIII Table 2-5.2 to allow for flange rotation.

1. Compute the full surface sealing area of the gasket, Ag (in²)

$$Ag = 0.7854 \cdot (OD^2 - ID^2) \text{ or } 3.14 \cdot (Go - N) \cdot N \quad Ag = \text{_____} \text{ in}^2$$

How to Find Gasket Stress at Assembly (Sya) Symbols and Units

- Sg = The stress on the sealing area of the gasket (psi)
- Sya = The PVRC uses this symbol for the design assembly seating stress or joint contact unit seating load (psi)
- Fp = Bolt preload in each bolt at assembly (lbs)
- FGA = Total nominal clamping force on the gasket at assembly (lbs)

- Sa = bolt stress at ambient temperature (psi)
- K = Nut factor (dimensionless)
- D = nominal diameter of bolt (inch)
- 12 = Divide Torque by 12 to convert from ft-in to ft-lb
- C = 0.0833; conversion Factor, Torque (ft-in to ft-lbs)
- Ar = Root cross-section area of a bolt (in²)
- Ab = Ar * number of bolts, (n)

Bolt Load

1. Compute, the nominal bolt preload in each bolt at assembly (lbs.). For example, if preload is specified by torque (T; ft./lbs.) then

$$Fp = 12 \cdot T / K \cdot D \quad \text{_____} \text{ lbs}$$

2. Compute, if preload is specified by the actual total cross-sectional area of bolts at root of thread or section of least diameter under stress, (Ar), then multiply Ar by the bolt stress, Sa.

$$Fp = Ar \cdot Sa = \text{_____} \text{ lbs}$$

You can convert the final nominal preload to nominal Torque:

$$T = K \cdot D \cdot Fp / 12 = \text{_____} \text{ Ft/lbs}$$

- 3) Compute the total, nominal clamping force on the gasket at assembly (FGA; lbs.), n = number of bolts. Ab = Ar * number of bolts (n)

$$FGA = n \cdot Fp = \text{_____} \text{ lbs (or)}$$

$$FBA = Ab \cdot Sa = \text{_____} \text{ lbs}$$

Gasket Stress

4. Compute the initial gasket stress (Sya)

$$Sya = FGA / Ag = \text{_____} \text{ psi}$$

After the assembly, you then calculate the pressure load on the joint, estimate how much the pressure load will partially relieve the joint and compute the net clamping force on the joint after the system has been pressurized. For reference, go to the pages titled PVRC Method.

Effective Gasket Seating Width

	Facing Sketch (Exaggerated)	Basic Gasket Seating Width, b_o	
		Column I	Column II
(1a)		$\frac{N}{2}$	$\frac{N}{2}$
(1b)			
See Note (1)		$\frac{w+T}{2}; \left(\frac{w+N}{4} \text{ max.}\right)$	$\frac{w+T}{2}; \left(\frac{w+N}{4} \text{ max.}\right)$
(1c)			
(1d)		$\frac{w+N}{4}$	$\frac{w+3N}{8}$
See Note (1)			
(2)		$\frac{N}{4}$	$\frac{3N}{8}$
1/64 in. Nubbin			
(3)		$\frac{3N}{8}$	$\frac{7N}{16}$
1/64 in. Nubbin			
(4)		$\frac{N}{4}$	$\frac{3N}{8}$
See Note (1)			
(5)		$\frac{w}{8}$...
See Note (1)			
(6)			

- N = Width of gasket
- W = Width of contact area (raised face or serrations)
- T = Thickness of gasket
- b_o = Basic seating width of gasket
- b_1 = Effective seating width of gasket

$$b_1 = b_o \text{ if } b_o \leq 1/4";$$

$$b_1 = (\sqrt{b_o})/2 \text{ if } b_o > 1/4"$$

* Where serrations do not exceed 1/64" in depth and 1/32" width spacing, choose 1b or 1d.

Effective Gasket Seating Width, b_o
 $b = b_o$, when $b_o \leq 1/4$ in.; $b = 0.5 \sqrt{b_o}$, $b_o > 1/4$ in.

Location of Gasket Load Reaction

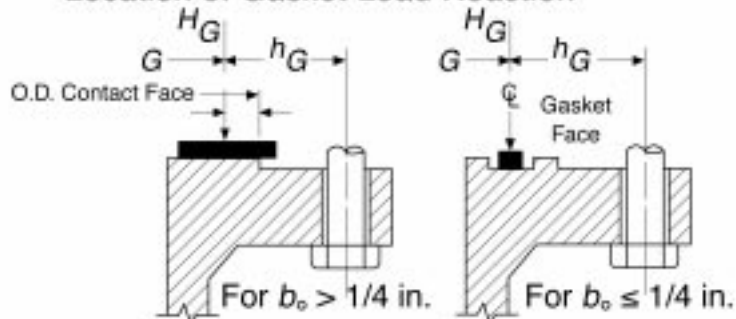

WARNING:

Properties/applications shown throughout this brochure are typical. Your specific application should not be under taken without independent study and evaluation for suitability. For specific application recommendations consult Garlock. Failure to select the proper sealing products could result in property damage and/or serious personal injury.

Performance data published in this brochure has been developed from field testing, customer field reports and/or in-house testing.

While the utmost care has been used in compiling this brochure, we assume no responsibility for errors. Specifications subject to change without notice. This edition cancels all previous issues. Subject to change without notice.

Gasket Factors M & Y

“M” and “Y” data are to be used for flange designs only as specified in the ASME Boiler and Pressure Vessel Code Division 1, Section VIII, Appendix 2. They are not meant to be used as gasket seating stress values in actual service. Our bolt torque tables give that information and should be used as such.

“M” - Maintenance Factor

A factor that provides the additional preload needed in the flange fasteners to maintain the compressive load on a gasket after internal pressure is applied to a joint.











$$M = (W - A_2P)/A_1P$$

Where: W = Total Fastener force (lb. or N)
 A_2 = Inside area of gasket (in.² or mm²)
P = Test pressure (psig or N/mm²)
 A_1 = Gasket area (in.² or mm²)

“Y” - Minimum Design Seating Stress

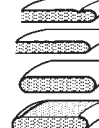
the minimum compressive stress in pounds per square inch (or bar) on the contact area of the gasket that is required to provide a seal at an internal pressure of 2 psig (0.14 bar).

$$Y = W/A_1$$

Gasket Design	Gasket Material	Gasket Factor "M"	Min. Design Seating Stress "Y" (psi)
Spiral wound metal, non-asbestos filled 	Stainless steel or MONEL®	3.00	10,000
Garlock CONTROLLED DENSITY® flexible graphite-filled spiral wound 	Stainless steel or MONEL®	3.00	7,500
Garlock EDGE® 	Stainless steel or MONEL®	2.00	5,000
Garlock GRAPHONIC® 	Stainless steel and Flexible Graphite Liquid service:	2.00 (1/16") 9.00 (1/8") 2.00	2,000 (1/16") 3,000 (1/8") 900
Corrugated metal, non-asbestos or Corrugated metal-jacketed, non-asbestos filled 	Soft aluminum Soft copper or brass Iron or soft steel MONEL® or 4%-6% chrome Stainless steel	2.50 2.75 3.00 3.25 3.50	2,900 3,700 4,500 5,500 6,500
Corrugated metal 	Soft aluminum Soft copper or brass Iron or soft steel MONEL® or 4%-6% chrome Stainless steel	2.75 3.00 3.25 3.50 3.75	3,700 4,500 5,500 6,500 7,600
Flat metal-jacketed, non-asbestos filled 	Soft aluminum Soft copper or brass Iron or soft steel MONEL® 4%-6% chrome Stainless steel	3.25 3.50 3.75 3.50 3.75 3.75	5,500 6,500 7,600 8,000 9,000 9,000
Grooved metal 	Soft aluminum Soft copper or brass Iron or soft steel MONEL® or 4%-6% chrome Stainless steel	3.25 3.50 3.75 3.75 4.25	5,500 6,500 7,600 9,000 10,100
Solid flat metal 	Soft aluminum Soft copper or brass Iron or soft steel MONEL® or 4%-6% chrome Stainless steel	4.00 4.75 5.50 6.00 6.50	8,800 13,000 18,000 21,800 26,000
Ring joint 	Iron or soft steel MONEL® or 4%-6% chrome Stainless steel	5.50 6.00 6.50	18,000 21,800 26,000

This table lists many commonly used gasket materials and contact facings with suggested design values of "M" and "Y" that generally have proven satisfactory in actual service when using effective gasket seating width B, described in the formula on page 10. The design values and other details given in this table are suggested only and are not mandatory.

MONEL® is a registered trademark of International Nickel.

Test Results - Overview

Room Temperature Tightness Test (ROTT)

Garlock Sealing Technologies certifies the results of two or more tests on 4-7/8" I.D. by 5-7/8" O.D. GRAPHONIC® series of gaskets with helium as media, and conducted in accordance with the Pressure Vessel Research Council Room Temperature Tightness Test (ROTT) procedure. Standard test criteria is represented below.

Requirement	Gb	a	Gs	S100	S1,000 (1.2)
Typical:	315	0.36	1.855	1.653	3,787

Notes:

1. The constants Gb, a and Gs shall be determined by the ROTT test procedure (See Reference 1).
2. S100 and S1000 are stresses (psi) respectively representing the values $G_b(100)^a$ and $G_b(1000)^a$.

Summary

Room Temperature Tightness tests (ROTT) were performed on gasket specimens at the École Polytechnique Gasket Test Facility. The tests show excellent tightness. On a range of loading and unloading stress levels, they are the tightest flexible graphite gaskets tested to date. By comparison to laminated graphite sheet, the initial leak rate of the gasket averaged about 100 times less at an initial gasket stress (Sg) of 8,000 psi.

Constants, Gb, a, and Gs: These are the constants used in formulas that give a design bolt load having the same meanings as the larger of Wm1 or Wm2 of the ASME Code. Gb, a and Gs are obtained by interpretation of leakage test data as plots of gasket stress (Sg) vs the tightness parameter, Tp on log-log paper. The values of Gb and Gs are determined by the intercepts of the loading and unloading lines with the $T_p = 1$.

Gb, a: What the gasket seating load should be, because Gb and a are associated with the seating load sequence (Part A data) of a gasket test. Gb represents the loading of the gasket (Intercept of the loading curve on the gasket stress Axis) at $T_p = 1$. The slope of the line is represented by a.

Gs: Gs is associated with the operating part of a gasket test, known as Part B, where the gasket is unloaded and reloaded as leakage is measured. Gs = Unloading intercept (intercept of the unloading curve on the gasket stress axis) at $T_p = 1$.

Tightness Parameter, Tp: The investigators discovered that test data could be summarized by use of a dimensionless tightness parameter. It is represented by Tp, expressed in terms of mass leak rate.

Tp is the pressure (in atmospheres) required to cause a helium leak of 1 mg/sec for a 150 mm (5.9 in.) OD gasket in a joint. A tightness parameter of 100 would mean that it takes an internal pressure of 1,470 psi (10.1 MPa) to create a total leak rate of about 1 mg/sec from a 6" OD gasket (152 mm) gasket. A 100 times less leak rate of 0.01 mg/sec at 1,470 psi would mean a tenfold increase in the tightness parameter to 1,000 Tp. Tp is proportional to pressure and inversely proportional to the square root of the leak rate. A higher value of Tp indicates a tighter joint.

$G_b(T_p)^a$: The value of $G_b(T_p)^a$ compares seating properties among gaskets when comparisons are made at representative values of Tp, such as 100 and 1,000. Such comparisons show the combined effect of Gb and a on the seating performance of a gasket. The new gasket constants will eventually replace the present ASME Code M and Y factors. The new constants, Gb, a and Gs help define the behavior of the gasket under all possible stress conditions. The only design guidance emerging from this work is the concept of "tightness" levels. Once the designer has learned how to convert Gb, a, Gs and selected tightness level to specific stress targets, he can design better flanges. The installer of gaskets will find the new gasket constants useful, since they genuinely define gasket behavior.

ROTT Test (contd)

Gasket Constants - Low Stress Interpretation

NPS 4" Corrugated GRAPHONIC® Gasket Style

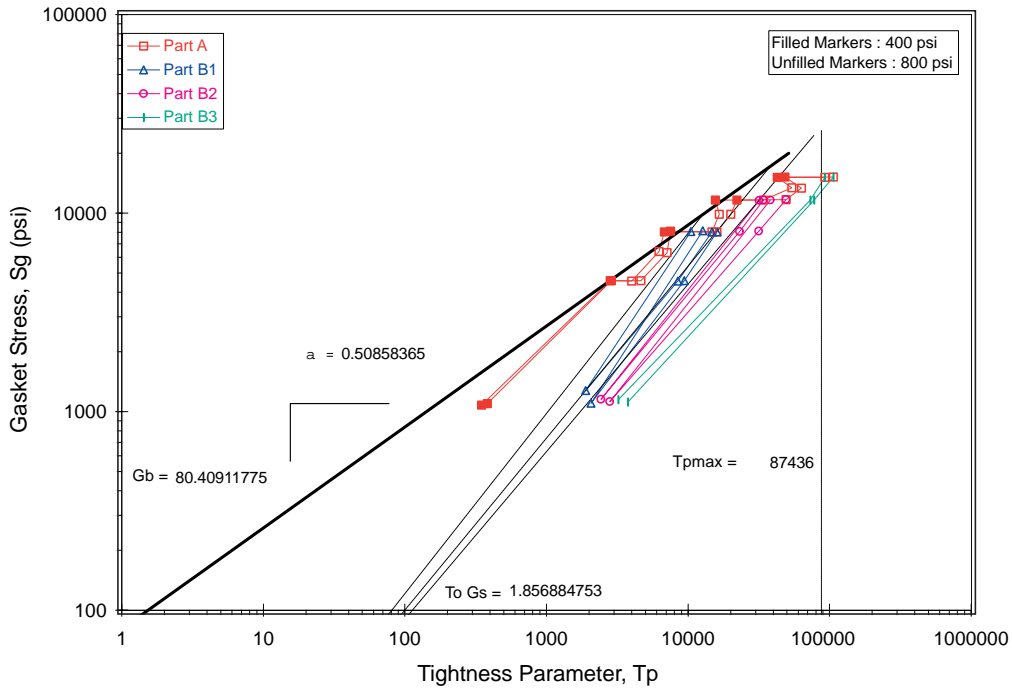

GET™ and GRAPHONIC® GR NPS4 CL 150

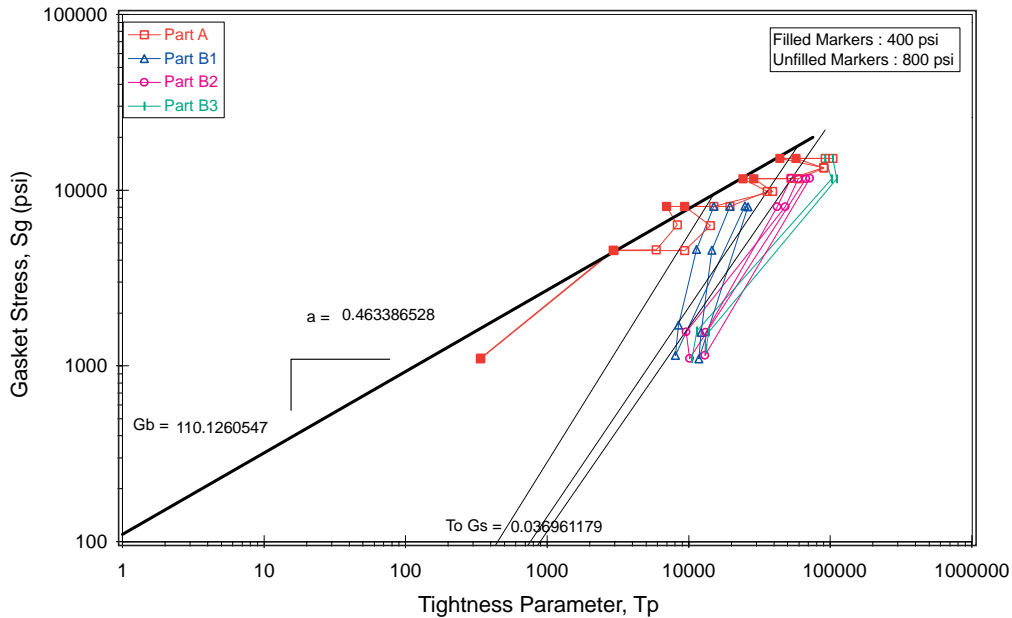

WARNING:

Properties/applications shown throughout this brochure are typical. Your specific application should not be under taken without independent study and evaluation for suitability. For specific application recommendations consult Garlock. Failure to select the proper sealing products could result in property damage and/or serious personal injury. Performance data published in this brochure has been developed from field

testing, customer field reports and/or in-house testing.

While the utmost care has been used in compiling this brochure, we assume no responsibility for errors. Specifications subject to change without notice. This edition cancels all previous issues. Subject to change without notice.

Gasket Constants - Crush Test

Introduction

A crush test was performed at room temperature on a GRAPHONIC® Series gasket specimen at the École Polytechnique Gasket Test Facility. The elastic recovery upon final unloading from the maximum stress of 40,000 psi shows that the GRAPHONIC® gasket performed very well subsequent to high gasket loading. Tightness kept improving as the gasket was compressed to higher loads. Leakage resistance to unloading was good and not affected by the imposed high stresses. It appears very difficult to crush the GRAPHONIC® gasket at room temperature.

Test Gasket

The test used a GRAPHONIC® gasket with 316 stainless steel corrugated core encapsulated by a 0.020" (0.5 mm) thick layer of flexible graphite on each side. The gasket contact surface is 8.44 square inches on a 5-7/8" O.D. x 4-7/8" I.D. specimen.

Test Procedure

During the crush test, the gasket is cycled from a minimum load of 1,025 psi up to the required maximum load of 40,000 psi by increments of 5,000 psi. Gasket deflection and leakage (with helium at 800 psig) are measured at every step. The details of the crush test procedure are as follows:

- 1 - The gasket specimen is initially loaded to a stress level of 15,000 psi. Gasket deflection measurements are taken at intermediate stress levels. A first leakage measurement is taken at the 15,000 psi stress level.
- 2 - The gasket specimen is unloaded to a stress level of 1,025 psi. The compressive stress is then increased to the next stress level incremented by 5,000 psi. The cycle is repeated up to the maximum gasket stress of 40,000 psi.

Test Results and Analysis

The first plot shows gasket stress, S_g , versus tightness, T_p , on log-log scales. The Tightness

Parameter, T_p , represents the inverse of leakage and may be thought of as the number of atmospheres of pressure needed to cause a leak of 1 mg/sec of helium. Thus, a high T_p is good.

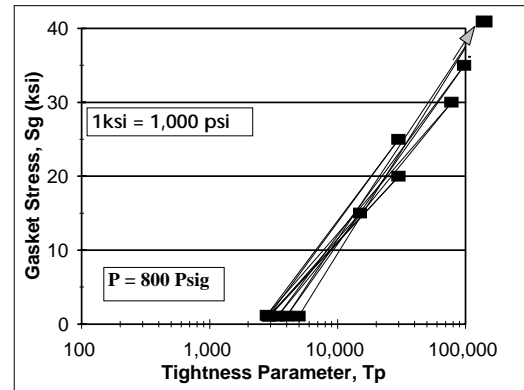

Note that the tightness increased to a value of 124,000 (T_p) as the specimen was compressed to increasingly higher loads. The leakage resistance to unloading was good even when the gasket was crushed to the higher loads.

The plot below shows gasket stress, S_g , versus gasket deflection, D_g .

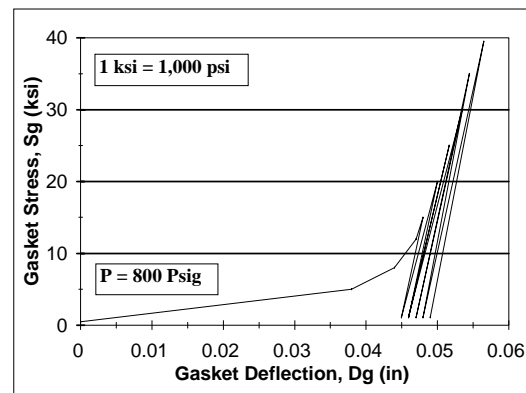

The GRAPHONIC® gasket has good deflection recovery in each one of the unloadings shown. The unload-reload lines are almost parallel, which means that the mechanical behavior of the gasket was not affected by the imposed high loads. The elastic deflection recovery upon final unloading from the maximum compressive stress of 40,000 psi to the 1,025 psi stress level is of approximately 3.7 mils.

Gasket Leak Rate T3 vs Gasket Stress

In the leak tightness tests of graphite-based gaskets, no other gasket outperformed the GRAPHONIC® Series of Gaskets. Tests confirm the ability of the GRAPHONIC® Series of Gaskets to seal at less than 1/2 the bolt load or gasket stress of other leading graphite-type gaskets. The GRAPHONIC® Series of Gaskets are the best gasket to achieve a tight seal without over-stressing the flange assembly.

Allowable Leak Rate T3 (Tight) vs. Gasket Stress

T3 (Tight) represents a Mass Leak Rate Per Unit Diameter (L_{RM}) of (1/50,000) 0.00002 mg/sec-mm* OR (1/248,000) 0.000004 lbm/hr-in.**

*Milligrams per second per millimeter of gasket outside diameter. **Pounds per hour per inch of gasket outside diameter.

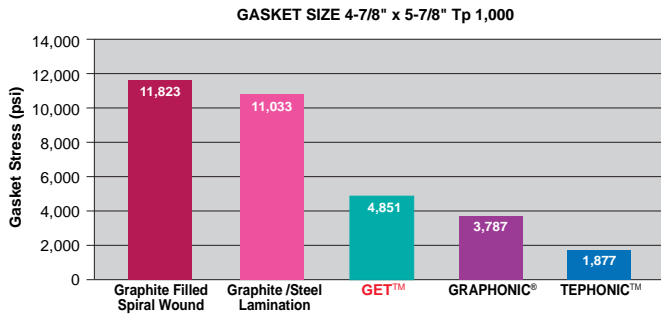

Superior Sealing Characteristics

On initial loading to stress levels over 11,600 psi, it was difficult to detect leak rates at 800 psi internal pressure with a detection system that is capable of resolving 1/100,000 milligrams per second of helium. This level of tightness is rarely seen in any gasket.

Low (Tight) Leak Rate in These Tests

Note that in volumetric terms the allowable leak rate T3 (tight) is approximately 0.45 liter/day (0.84 pint/day) of nitrogen gas at standard conditions for a 10 inch NPS joint.

WARNING:

Properties/applications shown throughout this brochure are typical. Your specific application should not be under taken without independent study and evaluation for suitability. For specific application recommendations consult Garlock. Failure to select the proper sealing products could result in property damage and/or serious personal injury.

Performance data published in this brochure has been developed from field testing, customer field reports and/or in-house testing.

While the utmost care has been used in compiling this brochure, we assume no responsibility for errors. Specifications subject to change without notice. This edition cancels all previous issues. Subject to change without notice.

Gasket Stress vs Mass Leakage

Low Initial Sealing

The GRAPHONIC® Series of Gaskets show an exponentially lower leak rate under the same load conditions. This advantage indicates a much more forgiving gasket in a wide range of initial bolt loading. This can translate into a higher margin of safety from potential “leakers,” thus providing additional evidence that the GRAPHONIC® Series of Gaskets are *THE RIGHT GASKET*.

Gasket Stress vs. Leak Rate

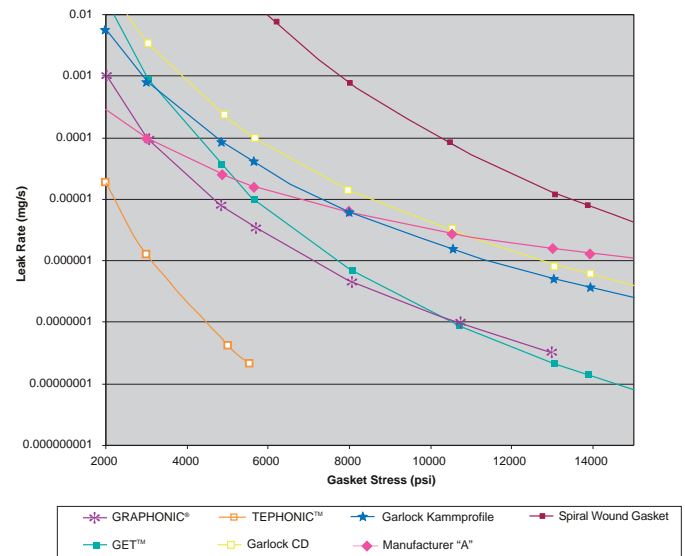

Gasket Stress vs. Tightness Parameter

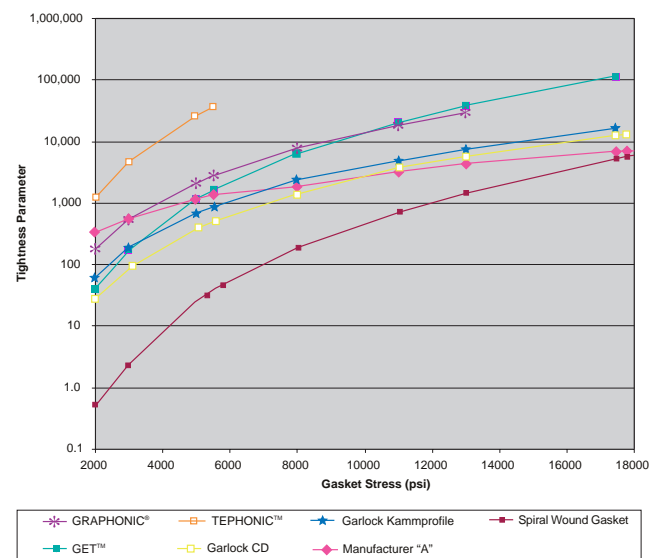

Mass Leak Rate to Volumetric Leak Rate

Since mass leak rates are difficult to visualize, we have calculated leak rates for Nitrogen and

Helium gases, with equivalents in terms of volumetric leak rates with a 12.75" (324mm) OD sealing contact.

MASS LEAK RATES:

Tc 3 Tight
Tc Standard
NPS joint 10" with a face OD of

1/50,000 mg/s per mm
1/500 mg/s per mm
324 millimeter

1/248,000 lb/hr per in
1/2,480 lb/hr per in
12.75 inches

mg = milligram mm = millimeter s = second in = inches

The mass leak rate is calculated on a per millimeter or inch basis of the outside diameter (OD) of the sealing contact surface.

NITROGEN weight*

Tc 3 (Tight), Allowable Leak Rate
Leak Rate of the NPS joint 10"***

Volumetric Leak Rate†

Tc 2 (Standard), Allowable Leak Rate
Leak Rate of the NPS joint 10"

Volumetric Leak Rate

HELIUM weight

Tc 3 (Tight), Allowable Leak Rate
Leak Rate of the NPS joint 10"

Volumetric Leak Rate

Tc 2 (Standard), Allowable Leak Rate
Leak Rate of the NPS joint 10"

Volumetric Leak Rate

	1.251 gram/liter	0.075261 lb/cu ft
Tc 3 (Tight), Allowable Leak Rate	0.00002 mg/sec/mm	0.000004 lb/hour/in
Leak Rate of the NPS joint 10"***	0.006477 mg/sec	0.000051 lb/hour
	560 mg/day	0.001234 lb/day
	0.560 gram/day	0.016 cu ft /day
Volumetric Leak Rate†	0.45 liter/day	0.84 pints/day
Tc 2 (Standard), Allowable Leak Rate	0.00200 mg/sec/mm	0.000403 lb/hour/in
Leak Rate of the NPS joint 10"	0.647700 mg/sec	0.005141 lb/hour
	55,961 mg/day	0.123387 lb/day
	55.961 gram/day	1.639 cu ft /day
Volumetric Leak Rate	45 liter/day	84 pints/day
	0.179 gram/liter	0.011143 lb/cu ft
Tc 3 (Tight), Allowable Leak Rate	0.00002 mg/sec/mm	0.000004 lb/hour/in
Leak Rate of the NPS joint 10"	0.006477 mg/sec	0.000051 lb/hour
	560 mg/day	0.001234 lb/day
	0.560 gram/day	0.111 cu ft /day
Volumetric Leak Rate	3 liter/day	6 pints/day
Tc 2 (Standard), Allowable Leak Rate	0.00200 mg/sec/mm	0.000403 lb/hour/in
Leak Rate of the NPS joint 10"	0.647700 mg/sec	0.005141 lb/hour
	55,961 mg/day	0.123387 lb/day
	55.961 gram/day	11.07 cu ft /day
Volumetric Leak Rate	314 liter/day	569 pints/day

Note: 51.4281 pints (U.S. dry) in a cu ft. cu ft = cubic feet

* Weights assume a dry gas at 0°C (32°F) and 760 mm Hg (14.70 pounds/sq inch).

** Leak rate of the gasket is calculated by multiplying the leak rate per mm (inch) by the smaller of the flange face or gasket OD.

† To calculate Volumetric Leak Rate:

Divide the leakage in gram/day by the weight of the gas (gram/liter) for liter/day.

Multiply the leakage in cu ft/day X pints in a cu ft (51.4281) for pints/day

Fire Integrity

To determine the ability of the GRAPHONIC® and GET™ Series of Gaskets to maintain tightness in a fire, two tests were conducted at École Polytechnique, Department of Mechanical Engineering, University of Montreal, Canada, Gasket Testing Facility. The test procedure was the FITT test (Fire Tightness Test) which gives a good indication of the survival potential of a gasket in a real fire. It measures leakage at realistic loads while rapidly heating and soaking a gasket at 1,200°F for 15 minutes.

At a gasket stress of 1,500 psi the Tightness Parameter, T_p , values increased nearly 20-fold to T_p of 2,800. This means that the leak rate decreased over 300-fold. For comparing performance, the T_p value of 32 represents the average performance of a well-aged compressed asbestos sheet material. From this test, it was concluded that the GRAPHONIC® and GET™ have fire integrity.

Fire Resistance Test (FITT)

Garlock Sealing Technologies certifies the results of two tests, conducted in accordance with the Pressure Vessel Research Council FITT Procedure 1.3 (Ref. 2) on NPS 4 GRAPHONIC® test gaskets exposed to a 20-minute heat-up plus 15 minute soak at 1200°F (649°C).

Required Post-exposure Minimum Tightness:

$T_{pmin} > 32$ (Helium)

Typical Post-exposure Minimum Tightness:

$T_{pmin} = 2000$ (Helium)

References:

1. Draft No. 8 "Standard Test Method for Gasket Constants for Bolted Joint Design", ASTM Committee F3, Payne, J., April 1991 (Not approved by ASTM).
2. Dereene, M., Payne, J.R., Marchand, L., and Bazerqui, A., "On The Fire Resistance of Gasketed Joints," *WRC Bulletin* No. 377, Dec. 1992.

WARNING:

Properties/applications shown throughout this brochure are typical. Your specific application should not be under taken without independent study and evaluation for suitability. For specific application recommendations consult Garlock. Failure to select the proper sealing products could result in property damage and/or serious personal injury. Performance data published in this brochure has been developed from field testing, customer field reports and/or in-house testing.

While the utmost care has been used in compiling this brochure, we assume no responsibility for errors. Specifications subject to change without notice. This edition cancels all previous issues. Subject to change without notice.

GET™ and GRAPHONIC® Exceed the Performance of Flexible Graphite Laminate Sheet

The post-exposure tightness of both the GET™ and GRAPHONIC® gaskets specimen exceeded that of flexible graphite laminate sheet and equaled graphite filled spiral wound gaskets.

WARNING: No matter how fire-safe the gasket, the bolted joint containing that gasket may open up under certain conditions of flame or fire-water impingement during a real fire. In a fire, the bolts get sloppy and stretch, separating the flange faces. But the GRAPHONIC® Series of Gaskets do not burn up. It stays in place, helping control the release. The result is valuable extra time to control the fire. Tests indicate that the GRAPHONIC® Series of Gaskets has the ability to regain tightness when cooled.

Test Procedure

1. A 5-7/8" O.D. x 4-7/8". I.D. GRAPHONIC® gasket was installed in the test rig within a heavy platen assembly.
2. The gasket was compressed to 4 levels from 1,025 psi up to 8,000 psi at room temperature and the leakage was measured. The load was reduced to 5,000 psi then the pressure and load were removed.
3. The hot loading platen was heated to 800°F and the gasket assembly was introduced.
4. Gasket stress of 1,500 psi was applied.
5. Applied 400 psi internal pressure with helium.
6. Maintained pressure until temperature stabilized at 1,200°F.
7. Held temperature and pressure for 15 minutes while the leakage rate was monitored.

Note: GET™ and GRAPHONIC® gaskets both passed the API 607 4th Edition Fire Test in October of 1996.

Performance Comparison Load Charts

You can visualize the new PVRC gasket constants using an X-Y graph with values in a logarithmic scale. The tightness parameter lies along the X axis, while the gasket stress is oriented along the Y axis. G_b is the gasket stress correlating to a tightness parameter of 1, in the case of a GRAPHONIC®, this value would be 315 psi. As gasket stress is increased, the tightness parameter increases, the slope of this relationship is “a”, again for the GRAPHONIC®, this value is 0.360.

Utilizing these numbers we can calculate the associated gasket stress to achieve a certain tightness parameter. The formula for this is:

$$S_g = G_b(tp)^a$$

The stress to achieve a tightness parameter of 1,000 is 3,780 psi and for a tightness parameter of 10,000, the gasket stress is 8,657.

Load Performance Comparison - Chart A

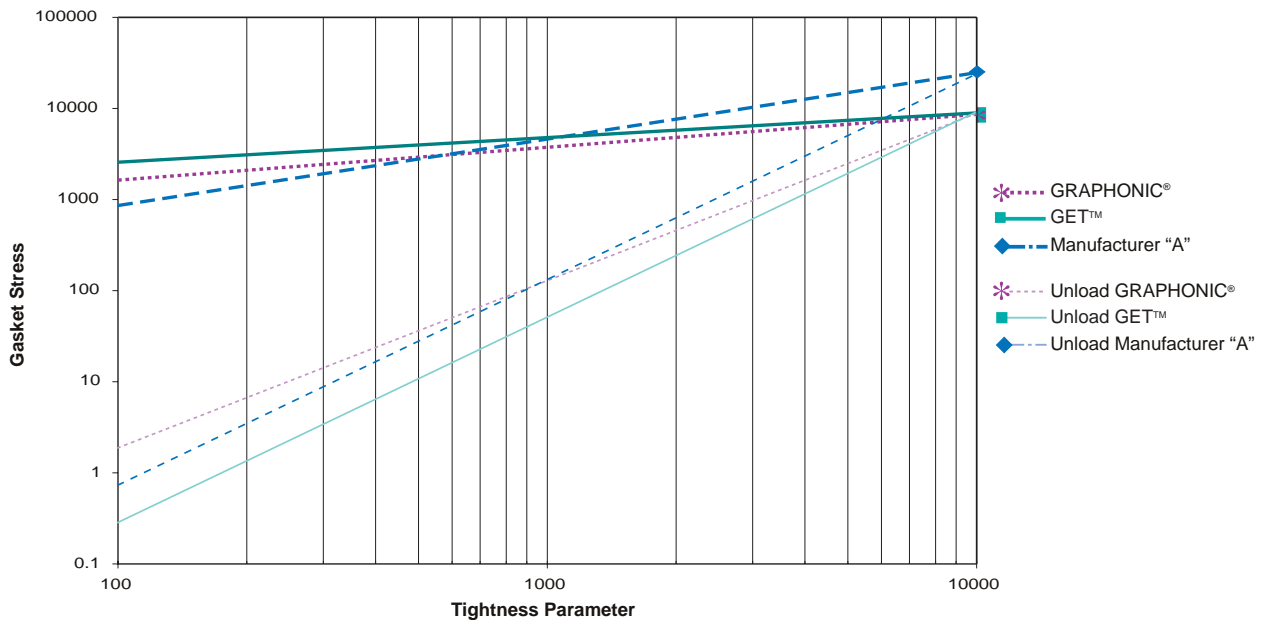

Load Performance Comparison - Chart B

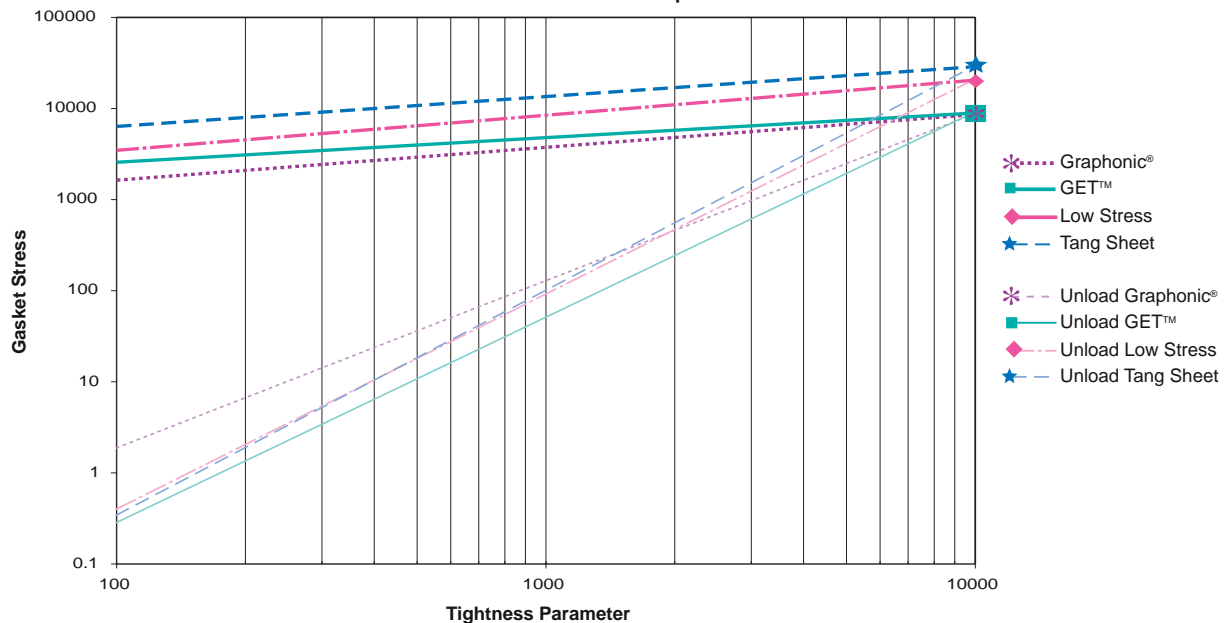

Performance Comparison Unload Charts

After seating, the connection is pressurized and the gasket can experience the effects of the hydrostatic end force that can unload the connection, reducing the gasket stress. The degree that the gasket loses sealability is reflected in the Gs constant. For the GRAPHONIC®, this value is 1.857. Again this unload curve can be seen on the graph below.

Gasket leak rates can be calculated from the unload portion of this curve. For specific calculations, please contact Garlock engineering.

From the charts below, it can be concluded that the GET™ and GRAPHONIC® show lower gasket stresses (over Tp 1,000) than other gaskets at all corresponding tightness parameters.

Unload Performance Comparison - Chart A

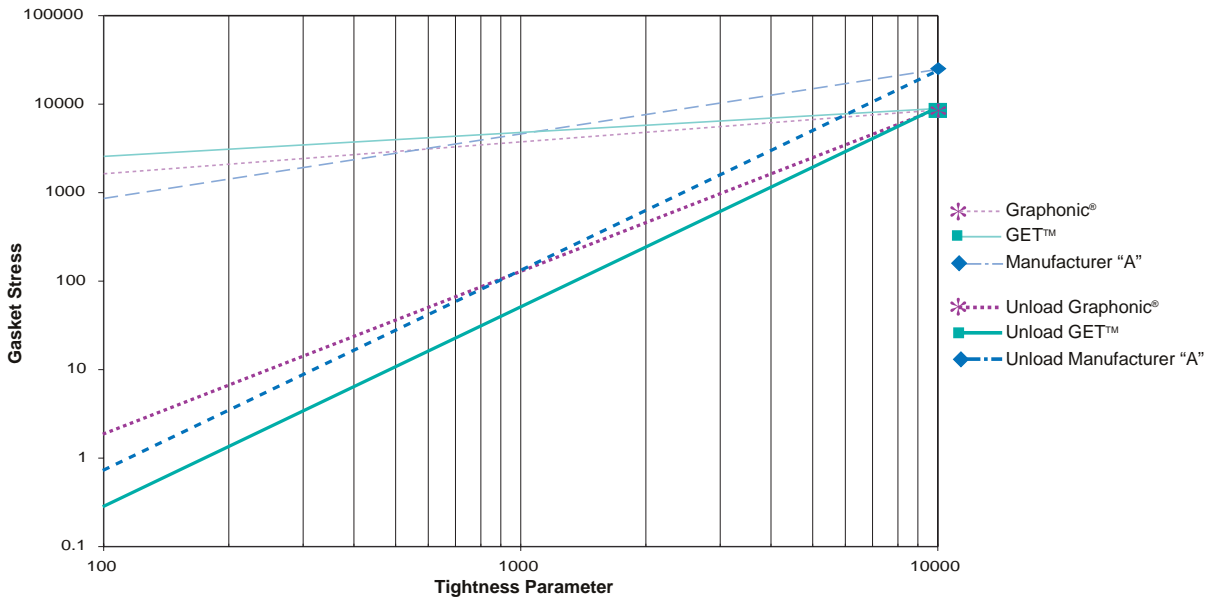

Unload Performance Comparison - Chart B

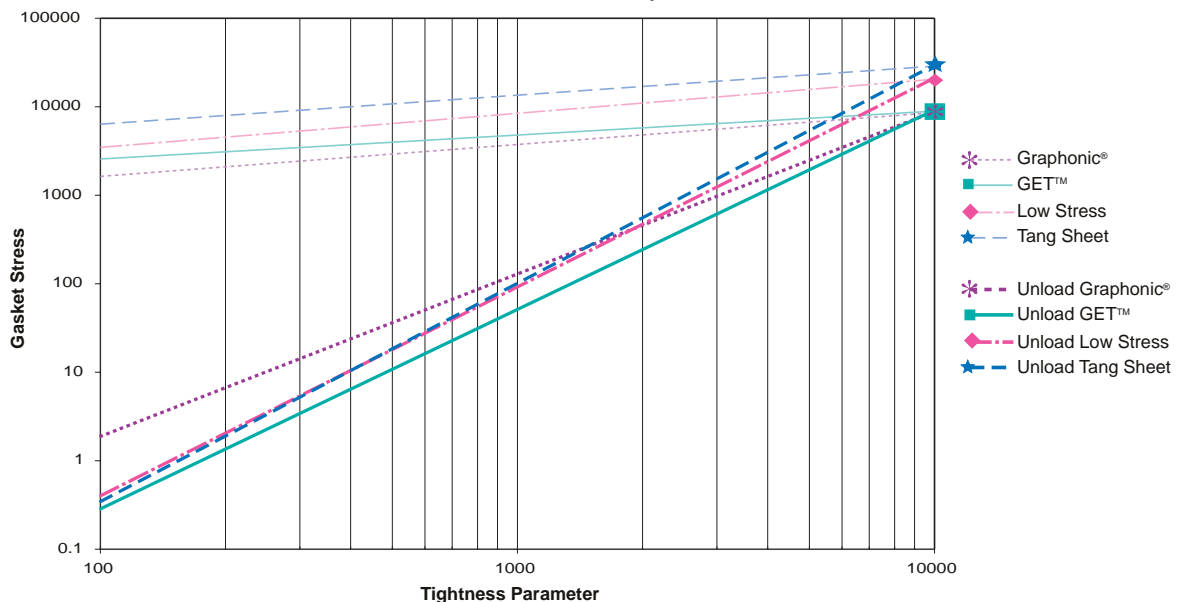

WARNING:

Properties/applications shown throughout this brochure are typical. Your specific application should not be under taken without independent study and evaluation for suitability. For specific application recommendations consult Garlock. Failure to select the proper sealing products could result in property damage and/or serious personal injury.

Performance data published in this brochure has been developed from field testing, customer field reports and/or in-house testing.

While the utmost care has been used in compiling this brochure, we assume no responsibility for errors. Specifications subject to change without notice. This edition cancels all previous issues. Subject to change without notice.

Gasket Constants

The gasket constants for the GRAPHONIC® Series of Gaskets compare favorably to those of other gaskets. Low values of (a) & Gs reflect a gasket that loads quickly under relatively low bolt loads and maintains a "tightness" during the unload portion of testing. The value of the expression $G_b(T_p)^a$ compares seating properties among gaskets when comparisons are

made at representative values of T_p (measure of tightness). Such comparisons show the combined effect of (G_b) and (a) on the seating performance of a gasket. The table below compares the value of $G_b(T_p)^a$, which indicates the seating stress required to meet a T_p (measure of tightness) for various gaskets.

T_p (100) Sg (psi)	T_p (1,000) Sg (psi)	TYPE	MATERIAL	G_b (psi)	a	Gs (psi)
2,590	4,850	GET™	SS/Graphite/PTFE	741	0.272	0.037
1,653	3,787	GRAPHONIC®	SS/Graphite	315	0.360	1.857
943	1,877	TEPHONIC™	SS/PTFE	238	0.299	6.46×10^{-7}
873	4,562	Manufacturer "A"	SS/Graphite	32	0.718	0.001
6,851	11,823	Spiral Wound	SS/Graphite	2,300	0.24	13
8,575	11,836	Spiral Wound	SS/PTFE	4,500	0.14	70
7,498	12,734	Spiral Wound	SS/Mica	2,600	0.23	15
13,536	27,007	Spiral Wound	SS/Asbestos	3,400	0.30	7
3,615	8,875	Flexitallic "LS"	SS/Graphite	600	0.39	2
8,364	14,204	Metal Jacketed	Soft Iron	2,900	0.23	15
8,364	14,204	Metal Jacketed	Stainless Steel	2,900	0.23	15
9,021	20,196	Metal Jacketed	Soft Copper	1,800	0.35	15
6,225	13,126	Laminated Graphite with Stainless	Tanged	1,400	0.33	0.01
4,631	11,033	with Stainless	Bonded	816	0.38	0.07
5,629	10,244	with Stainless	Screen	1,700	0.26	15
5,686	13,765	Flexible Graphite	Unreinforced	970	0.38	0.05
4,988	7,046	Compressed Elastomers reinforced with: 1/16" thick	Asbestos fibers	2,500	0.15	117
4,978	8,105	3/32" thick	Aramid fibers	1,900	0.21	14
		Expanded PTFE	For data on PTFE based gaskets, contact your Garlock representative			
		Filled PTFE				

$G_b(T_p)^a S_g$, (psi)
Sg = Gasket Stress

All data presented in this table is based on currently published information from the Pressure Vessel Research Council (PVRC) project for the ASME Special Working Group for Bolted Flanged Joints. The PVRC continues to refine data techniques and values are subject to further changes.

WARNING:

Properties/applications shown throughout this brochure are typical. Your specific application should not be under taken without independent study and evaluation for suitability. For specific application recommendations consult Garlock. Failure to select the proper sealing products could result in property damage and/or serious personal injury.

Performance data published in this brochure has been developed from field testing, customer field reports and/or in-house testing.

While the utmost care has been used in compiling this brochure, we assume no responsibility for errors. Specifications subject to change without notice. This edition cancels all previous issues. Subject to change without notice.

Glossary of Terms

Alloy: A homogeneous combination of two or more metals.

ANSI: American National Standards Institute.

API: American Petroleum Institute.

Asbestos: A fibrous mineral characterized by its ability to resist high temperatures and the actions of acids.

Ash: An impurity found in natural and other types of graphite and are ordinarily expressed in parts per million (ppm), or percent ash.

ASME: American Society of Mechanical Engineers, founded 1880, is an educational, technical and professional society of mechanical engineers and other qualifying individuals. ASME is an internationally recognized voluntary standards setting organization.

ASTM: American Society of Testing and Materials.

Atmospheric pressure: The weight of a column of air per area unit as measured from the top of the atmosphere to the reference point being measured. Atmospheric pressure decreases as altitude increases. ICAO sea level standard values = 14.696 pounds per square inch (0.1014 MPa).

Boiler and Pressure Vessel Code: A large document, maintained and published by the American Society of Mechanical Engineers (ASME). The code describes rules, material properties, inspection techniques, fabrication techniques, etc., for boilers and pressure vessels. It is sometimes referred to as the "Code".

Bolt load (pounds): A means of applying compressive load that flows the gasket material into surface imperfections to form a seal.

BSS: British Standards Specifications.

Calender: A machine containing rollers used in the flexible graphite industry, rubber industry and others, for compressing materials into continuous rolls, or sheets.

Cold flow: Continued deformation under stress.

Compressibility: The extent to which a gasket is compressed by a specified load. Permanent set is the unit amount, in percentage of the compressibility, that the material fails to return to the original thickness when the load is removed. Recovery is the amount of return to the original thickness in a given time, and is usually less under a prolonged load.

Compression: Stress from forces acting toward each other.

Corrosion: In broad terms, it is the destructive alteration of metal by chemical or electrochemical reaction within its environment, which encompasses not only atmospheric exposure but all the interacting conditions associated with a service application.

Corrugated, functionally: Wrinkled with a parallel series of ridges, grooves and hollows, or a parallel series of peaks and valleys or troughs, creating memory, springiness and resilience.

Creep: The slow, plastic deformation of a body under heavy loads. Independent variables which affect creep are time under load, temperature and load or stress level. It is the loss of tightness in a gasket measurable by torque loss.

Deflection: The deviation from zero shown by the indicator of a measuring device. The movement of a part as a result of stress.

Density: The ratio of mass of a body to its volume or mass per unit volume of the substance. For ordinary practical purposes, density and specific gravity may be regarded as equivalent.

DIN: Deutsches Institut für Normung. English translation is Germany Industry Standard – one of the European equivalents to ASTM.

Double-jacketed: A metal-jacketed gasket design that is entirely enclosed by the metal outer cover over a filler.

EPA: Environmental Protection Agency, a regulatory agency of the United States of America.

Glossary of Terms (contd)

Elastic interaction: The action by which bolts loosen as the adjacent bolts are tightened. The only theoretical way to prevent this is to tighten all bolts simultaneously. The most practical method is bolt torque using a crossing pattern, followed by retorques.

Elasticity: The ability of a material to return to its original form after the removal of the deforming force (stresses). A substance is highly elastic if it is easily deformed and quickly recovers. Metals, if deformed only a few percent, can be considered purely elastic.

Elongation: The increase in length of a stressed material.

Envelope gasket: The filler material is enclosed in an outer cover, typically of PTFE material, to enhance corrosion resistance.

Extrusion: Pressure forces a metal or plastic into a gap or opening.

Eyelet: Metallic inner eyelets are used to protect the gasket material from the sealed media. Blowout resistance and gas sealability can be improved depending on the correct choice of eyelet geometry and metal.

Fastener: A mechanical device for holding two or more bodies in definite positions with respect to each other.

Flange: The rigid members of a gasket joint that contact the sides or edges of the gasket.

Flat ring: A flange gasket lying wholly within the ring of bolts.

Flow, or creep: The gradual continuous distortion of a material under continued load.

Fluid: A fluid has the ability to flow and possesses mass. Examples of fluids are liquids such as water and blood.

Foot-pound: A unit of work equal to the energy required to raise one pound one foot.

Fulcrum: The point on which a lever turns.

Full-face gasket: Gasket covering the entire flange surface extending beyond the bolt holes.

Gas: Unlike molecules of a solid or liquid, gas molecules are not easily attracted to one another. They tend to remain separated. Gas molecules must be housed in a container or they will disperse and lose their integrity. An example of a gas is air.

Gasket constants G_b, a, G_s: G_b represents the initial loading curve relationship with tightness while G_s is the intercept of the unloading curve. The slope of the loading curve is represented by a.

Gasket stress: The contact pressure exerted on the gasket by the flange members.

GRAPHONIC®: Registered trademark of Garlock Sealing Technologies for a corrugated metal gasket with flexible graphite overlay (patent pending).

Heat exchanger, shell and tube: Metal shell with tubes inside designed to transfer thermal energy from one media to another. Most frequently the process stream fluid flows through the tubes and the heating or cooling fluid around the outside of the tubes in the shell.

Hooke's Law: Applying Hooke's Law, steel elongates 0.001 in. per 30,000 psi of applied stress.

Hydrostatic end force: A force created by the internal system pressure which attempts to open the two sealing surfaces. If the hydrostatic end force exceeds the bolting force, leaks and/or blowouts will occur.

Hydrostatic test pressure: A pressure used to test the integrity of a system, the hydro test pressure is typically one and a half times the anticipated system working pressure.

Hydrostatics: A branch of physics which deals with the pressure of fluids at rest.

ID: Symbol for inside diameter.

IFI: Industrial Fasteners Institute.

Initial preload: The tension created in a single bolt when the nut is first tightened. It is usual modified by subsequent assembly operations and/or by in-service loads and conditions.

Inorganic: Chemicals which do not contain carbon.

Glossary of Terms (contd)

Iterative: Characterized by repetition.

JIS: Japanese Industrial Standards.

Jointing: Common term in Europe for Gasketing.

Leakage rate: The quantity, either mass or volume, of fluid passing through and/or over the faces of gaskets in a given length of time.

Liter: A metric unit of volume equal to a cubic decimeter (1,000 cm³), or approximately 1.056 U.S. liquid quart. 1 liter contains 1,000 cubic centimeters of approximately 1 kilogram of water at 4°C (40°F)

“M” Maintenance value: An empirical design constant of a flange gasket used in the ASME Boiler and Pressure Vessels Code. The Code equation defines this term as the ratio of residual gasket load to fluid pressure at leak, dimensionless. The definition of “M” has varied in successive editions of the Code, according to the method employed for computing residual gasket load.

Mass: The measure of the quantity of matter.

Milligram: One thousandth of a gram.

Milliliter: One thousandth of a liter, equivalent to one cubic centimeter (1 cm³).

Modulus of elasticity: The ratio of the unit stress to unit strain within the elastic limit without fracture.

MSS: Manufacturer’s Standardization Society of the Valve & Fittings Industry.

MTI: Materials Technology Institute of the Chemical Process Industries.

Nut Factor: (K) An experimental constant used to evaluate or describe the ratio between the torque applied to a fastener and the preload achieved as a result. For example, torque vs. preload, (short-form equation)

(T) torque = (Fp) achieved preload (lb, N) x (K) nut factor x (D) nominal diameter (in., mm).

OD: Symbol for outside diameter.

Oxidation: The act of uniting, or causing a substance to unite with oxygen chemically.

Pascal: A SI unit of pressure equivalent to one Newton per square meter.

Pascal’s law: Describes the ability of gas or liquid to transmit pressure equally in all directions throughout itself.

Permeability: The quality or condition of allowing passage of fluid through a material.

Pi: The symbol which denotes ratio of the circumference of a circle to its diameter.

Pitch: The nominal distance between two adjacent thread roots or crests.

Preload: A clamping force expressed in pounds, which denotes the amount of tension force created that holds two or more pieces together when a fastener is tight.

Pressure: A measure of a force’s intensity. To determine pressure, the total force is divided by the area (usually square inches) on which it is acting. The result is the pressure (amount of force per square inch).

Pressure, atmospheric: Pressure exerted by the atmosphere at any specified location. Sea level pressure is approximately 14.7 pounds per square inch absolute.

Pressure, gage: Pressure differential above or below atmospheric pressure, expressed as pounds per square inch gage (psig).

Proof load: The maximum, safe, static, tensile load which can be placed on a fastener without yielding it. Proof load is an absolute value, not a maximum or minimum. Sometimes given as a force (lb, N) sometimes as a stress (psi, MPa).

PTFE: Polytetrafluoroethylene plastic.

PVRC: Pressure Vessel Research Council sponsored by the Welding Research Council.

WARNING:

Properties/applications shown throughout this brochure are typical. Your specific application should not be undertaken without independent study and evaluation for suitability. For specific application recommendations consult Garlock. Failure to select the proper sealing products could result in property damage and/or serious personal injury. Performance data published in this brochure has been developed from field testing, customer field reports and/or in-house testing.

While the utmost care has been used in compiling this brochure, we assume no responsibility for errors. Specifications subject to change without notice. This edition cancels all previous issues. Subject to change without notice.

Glossary of Terms (contd)

Raised-face flange: A flange which contacts its mating joint member only in the region in which the gasket is located. The flanges do not contact each other at the bolt circle.

Recovery: The ability of the gasket to spring back after the compressive load is reduced.

Relaxation: The loss of tension, and therefore clamping force, in a bolt and joint as a result of creep, thermal expansion, embedment, etc.

Residual load: The remaining measurable bolt load after the joint has relaxed and/or the system pressure has been relieved.

Resilience: The property of a material (stiffness/recovery) that enables it to resume its original shape or position after becoming bent, stretched, or compressed; elasticity.

Ring gasket: A flange gasket lying wholly within the ring of bolts. Also flat ring or raised face gasket.

Ring joint gasket: A solid metal ring gasket having either octagonal or oval cross-sections used in conjunction with flanges that are grooved to accept a gasket.

Root diameter area: ASME Code mandates the use of root diameter area rather than tensile stress area. The expression for this area is:

$$A_r = 0.7854(D - 1.3/n)^2$$

D = is the nominal diameter

n = is the number of threads per inch

SI (International System of Units): is a modernized and internationally standardized version of the metric system based on the meter, second, kilogram, ampere, degree Kelvin, and candela.

Sealability: A measure of fluid leakage through and across both faces of a gasket.

Spiral wound gasket: A gasket which is formed by winding spring-like metal, usually "V" shaped, and a suitable filler layer into a spiral.

Springback: A measure (percent) of the distance a gasket recovers from an initial compressive load.

Strain: A measure of the deformation that stress causes.

Stress: The applied force divided by the area. An applied force or system of forces that tends to strain or deform a body.

Stress corrosion cracking (SCC): A common form of stress cracking in which an electrolyte encourages the growth of a crack in a highly stressed bolt.

Stress relaxation: A transient stress-strain condition in which the gasket stress decays as the strain remains constant.

TEMA: Tubular Exchanger Manufacturers Association.

Tensile: Pertaining to extension or tension. Tensile strength is that strength necessary to enable a bar or structure to resist a tensile strain.

Tensile strengths: They are normally expressed in terms of stress-pounds per square inch (psi).

Tensile stress area: The effective cross-sectional area of the threaded section of a fastener. Used to compute average stress levels in that section. Based on the mean of pitch and minor diameters. ($A_s = 0.7854(D - 0.9743/n)^2$)

Tension: Stress from forces that are acting away from each other.

Tension, bolt: Tension (tensile stress) created in the bolt by assembly preloads and/or thermal expansion, service loads, etc.

Tensioner: A hydraulic tool used to tighten a fastener by stretching it rather than by applying a substantial torque to the nut.

TEPHONIC™: Trademark of Garlock Sealing Technologies for a family of PTFE gaskets.

TEX-O-LON®: Registered trademark of Goodrich for a gasket composed of perforated steel encapsulated with PTFE.

Thermal: Relating to heat; caused by heat.

Tightness: A measure of the mass leak rate from a gasketed joint.

Tightness parameter: A dimensionless parameter which defines the mass leakage of a gasket as a function of contained pressure and a contained fluid constant.

Glossary of Terms (contd)

Tongue-and-groove joint: A flange joint in which one flange is provided with a tongue (male) and the other with a groove (female).

Torque: The twisting moment, a product of force and wrench length, applied to a nut or bolt.

Ultimate strength: The maximum tensile strength a bolt or material can support prior to rupture. Always found in the plastic region of the stress strain of force-elongation curve, and so is not a design strength. Also called tensile strength and ultimate tensile strength.

UNS: United Numbering System, an alphanumeric designation to identify any metal or alloy; not a specification. UNS consists of a single uppercase letter, followed by five digits.

Vaaler awards: Award given to winners of a competition sponsored by Chemical Processing magazine. It is named after John C. Vaaler (1899-1963) who served as Editor from 1946 to 1963. The competition was developed to recognize significant technical advances in the Chemical Process Industries.

Viscosity: A measure of the resistance of a liquid's molecules to flow or slide past each other.

Viscous: Viscous materials dissipate, as heat, the energy used to deform them. Liquids such as water or mineral oil can be considered viscous.

Volume: The size or extent of a three-dimensional object or region of space.

“Y” factor: The initial gasket stress (psi, Mpa) of surface pressure required to preload or seat the gasket to prevent leaks in the joint as the system is pressurized.

Yield strength: The tension-applied load required to produce a specified amount of permanent deformation in a solid material.

Appendix

PVRC Method Introduction

To help improve designs, an ASME Special Working Group (SWG/BFJ) is working to implement gasket constants derived from hundreds of PVRC sponsored gasket tests. The result is a new modern method of flanged joint design that takes into account a design leakage rate as well as pressure and other loads. The concept of tightness is introduced in the new method as a design condition to ensure that a specified minimum leak rate is met. Tightness is the internal pressure needed to cause a certain small leak rate in a joint. Tightness is expressed through a Tightness Parameter, T_p .

Also, an ASTM task group (F3.40.21) is evaluating the PVRC gasket tightness performance test (The Room Temperature Tightness Test or ROTT) as a draft ASTM Standard Test. The new ASTM standard gasket test will be designed to elicit the gasket constants G_b , a and G_s for gasket materials.

The following is a paraphrase of proposed new ASME flanged joint design rules. Note that these rules are not completely finalized and could change. Note also that these rules apply to new designs. As seen below, a simpler offshoot of these rules may be considered for standard piping joints or existing joints. See page 30 for explanations of notations used in the following equations.

General Requirements

In the design of a bolted flange connection, calculations shall be made for design conditions including pressure, external loads and tightness.

Design Requirements

Tightness

Joints are to be designed to satisfy a tightness requirement that is established by the selection of a Tightness Class that is appropriate for the service conditions. The minimum required tightness, T_{pmin} , recognizes a maximum permitted leak rate for the selected Tightness class, T_c . The Tightness class is a value of T_c for use in Formula (1). T_c shall be selected for the desired tightness class. The minimum tightness requirement, T_{pmin} , shall be satisfied

in operation after the application of pressure and any external loads. T_{pmin} is determined by Formula (1), but shall not be less than 1.1:

$$T_{pmin} = 0.1243(T_c)P \quad (1)$$

TIGHTNESS CLASSES AND CATEGORIES			
Tightness Class	Tightness Class Factor, T_c	Leak Rate, lbHe/hr/in diameter	Leak Rate, mgHe/sec/mm diameter
1	0.1	1/25	1/5
2	1.0	1/2500	1/500
3	10.0	1/250000	1/50000

Assembly Tightness

The assembly tightness, T_{pa} , is a value of the tightness parameter greater than T_{pmin} . T_{pa} must be achieved by sufficient gasket compression at the time of joint assembly to ensure that T_{pmin} is achieved in operation. T_{pa} is determined by Formula (2) and sets the value of the design assembly seating gasket stress S_{ya} in Formula (5).

$$T_{pa} = X T_{pmin} \quad (2)$$

X must be between 1.5 and T_{pmax}/T_{pmin} . Any value of X within this range will produce an acceptable design. Selecting an X value so that S_{m3} equals S_{m1} finds the lowest gasket stress that will ensure the design tightness and the lowest required bolt load, and value of A_m . (If $S_{m1} > S_{m3}$, then increase X , and if $S_{m1} < S_{m3}$ then decrease X). This iterative design method is suitable for all gaskets including gaskets with compression stops and gaskets that exhibit hardening. For gaskets with compression stops that are not listed in Table 1, the value of T_{pmax} is to be determined by the designer in consultation with the manufacturer.

WARNING:

Properties/applications shown throughout this brochure are typical. Your specific application should not be undertaken without independent study and evaluation for suitability. For specific application recommendations consult Garlock. Failure to select the proper sealing products could result in property damage and/or serious personal injury. Performance data published in this brochure has been developed from field testing, customer field reports and/or in-house testing.

While the utmost care has been used in compiling this brochure, we assume no responsibility for errors. Specifications subject to change without notice. This edition cancels all previous issues. Subject to change without notice.

Appendix (contd)

Gasket Assembly

Minimum Initial Gasket Stress: During assembly, a minimum initial gasket stress is required to seat the gasket. The design gasket stress, S_{ya} , considered to be adequate for proper seating, is a function of the gasket material, the design pressure, the tightness class, and the assembly method per Formula (3) below. Increasing S_{ya} decreases S_{m1} but increases S_{m2} and S_{m3} . An optimum required bolting area results by applying an iterative process that sets S_{m1} equal to S_{m3} , as in (b):

$$S_{ya} = (G_b / \eta) (T_{pa})a \quad (3)$$

where G_b and a are given in Table 1, and assembly efficiencies, η , are as follows:

- $\eta = 1.00$ for "ideal" bolt-up, i.e. ultrasonics or direct stud stretch control
- 0.95 for very good bolt-up i.e. hydraulic tensioners
- 0.85 for well-controlled bolt-up i.e. torque wrench
- 0.75 for manual bolt-up

Operating Gasket Stresses

Gasket Operating Conditions: A minimum gasket stress must be maintained in operation to assure that the desired tightness will be achieved. This minimum required operating gasket stress is S_{m1} given by Formula (4) and the value of k is by Formula (5):

$$S_{m1} = G_s [T_{pmin}]^k \quad (4)$$

$$k = \text{Log}(\eta S_{ya}/G_s) / \text{Log}(T_{pa}) \quad (5)$$

The minimum operating gasket stress after the application of pressure and external loads, S_{m2} , is given by Equation (6a):

$$S_{m2} = (S_b/S_a) (\eta S_{ya}/1.5) - (P_{Ai} + F_A) / (A_g + A_p) - 4QM_E / GA_g \quad (6a)$$

If there are no external forces use:

$$S_{m2} = (S_b/S_a) (\eta S_{ya}/1.5) - (P_{Ai}) / (A_g + A_p) \quad (6a)$$

The average design operating gasket stress after

pressure and external loads are applied, S_{m3} , is given by Equation (6b):

$$S_{m3} = (S_b/S_a) (S_{ya}/1.5) - (P_{Ai} + F_A) / (A_g + A_p) - 4QM_E / GA_g \quad (6b)$$

If there are no external forces use:

$$S_{m3} = (S_b/S_a) (S_{ya}/1.5) - (P_{Ai}) / (A_g + A_p) \quad (6b)$$

The factor Q is taken as 1.0 unless calculated by rational means.

Required Bolt Load

The bolt loads used to calculate the required net cross-sectional area of bolts at root of threads or reduced section, if less, is determined as follows.

(a) The operating bolt load, W_{mo} , shall be sufficient to resist the hydrostatic end force H exerted by the design pressure on the area bounded by G , external loads, F_A and M_E . In addition, W_{mo} shall maintain on the gasket or joint-contact surface a compression stress equal to or greater than S_{mo} .

(b) The required operating bolt load, W_{mo} , is determined by Equation (7):

$$W_{mo} = P_{Ai} + S_{mo} (A_g + A_p) + F_A + 4QM_E / G \quad (7)$$

where S_{mo} is the largest of S_{m1} , S_{m3} , $2P/\eta$ and Sl/η .

(c) For flange pairs separated by a plate such as a tubesheet, W_{mo} is equal to the larger of the bolt loads calculated by Equation (7) for each flange individually.

Appendix (contd)

Bolt Areas and Maximum Permitted Gasket Assembly Stress

(a) Bolt Areas, A_m and A_b . The total cross-sectional area of bolts A_m required for both the operating condition and gasket seating is given by Equation (8a)

$$A_m = W_{mo}/S_b. \quad (8a)$$

(b) The bolts to be used shall be made so that the actual total net cross-sectional area of bolts A_b will not be less than A_m .

(c) Limit on A_b . Actual seating bolt load shall not exceed the maximum gasket assembly stress (S_c) and shall satisfy the expression:

$$1.5 (2 - \eta) A_b S_a < S_c (A_g + A_p) \quad (8b)$$

loss of assembly bolt load due to thermal effects, aging and other factors may be considered optionally.

The MOBL is determined as follows:

$$MOBL = S_{m1f} (A_g + A_p) + P A_i + F A + \frac{4 M_E}{G} \quad (9f)$$

Where:

$$S_{m1f} = G_s (T_{pmin})^{k_f} \quad (10a)$$

$$k_f = \log [S_{yaf}/G_s] / \log [T_{paf}] \quad (10b)$$

$$T_{paf} = [S_{yaf}/G_b]^{(1/a)} < T_{pmax} \quad (10c)$$

$$S_{yaf} = MABL / (A_g + A_p) \quad (10d)$$

Bolt Loads

Flange Design Bolt Load W : The bolt load used in the design of the flange shall be the value obtained from Formulas (9a) or (9b)

(a) Bolt-up Condition:

$$W = A_b (S_a) \quad (9a)$$

(b) Operating (Hot) Condition:

$$W = A_b (S_b) \quad (9b)$$

Minimum Assembly Bolt Load (MABL): The minimum assembly bolt load, for a test pressure of P_t , is the largest of the following three equations:

$$W_{a1} = (1/\eta)[S_{mo} (A_g + A_p) + P_t A_i] \quad (9c)$$

$$W_{a2} = P_t A_i (1/\eta - 1) + S_{ya} (A_g + A_p) \quad (9d)$$

$$W_{a3} = 1.5 A_b S_a \quad (9e)$$

Minimum Operating Bolt Load (MOBL): The assembly bolt load relaxes following assembly as a result of short-term permanent deformation of the gasket, and other factors. The available margin for relaxation is the difference between the MABL and MOBL. The joint bolt load should be capable of maintaining a load greater than the MOBL in operation after the effects of short-term factors. Long-term

Appendix (contd)

Application to Standard and Existing Joints

For standard piping joints or an existing non-standard joint, such as an exchanger girth joint, the problem is different and it can be somewhat simpler. Given that a gasket has been selected, the questions are what assembly torque should be used? And what is the leak rate, or the tightness class?

Minimum Assembly Bolt Load (MABL)

The MABL may be exactly calculated using the above formulas. Or, if sufficient, an approximate MABL may be found without iteration as outlined by the two methods below. In the case of an existing or standard flange the flange type and geometry, including the actual bolt area, A_b , are known.

MABL Approximate Method 1

T_{pmin} is determined as before from Formula (1)

$$T_{pmin} = 0.1243(T_c)P \quad (1)$$

A final assembly gasket stress, S_{yaf} , can be determined from the MABL and MOBL formulas, above. At this point however, MABL which depends on W_{a1} and W_{a2} , must be estimated because S_{mo} in W_{a1} and S_{ya} in W_{a2} , are unknown. A good estimate of MABL can be obtained as follows:

- (1) Calculate S_{m1} and S_{ya} from Formulas (2 and 4) as above using $X=1.5$.
- (2) Calculate S_{m3} from Formula (6b) and
- (3) Evaluate $S_{mo} =$ the largest of S_{m1} , S_{m3} , $2P/\eta$, Sl/η .
- (4) Calculate W_{a1} , W_{a2} and W_{a3} and
- (5) Determine MABL = the largest of W_{a1} , W_{a2} and W_{a3}

MABL Approximate Method 2

Although quicker, this method may be overly conservative because it refers to T_{pmax} . It works as follows:

- (1) Calculate W_{a1} using for S_{mo} the largest of $2P/\eta$, or Sl/η , psi
- (2) Calculate W_{a2} using T_{pmax} for S_{ya} :
 $S_{ya} = (Gb/\eta) (T_{pmax})a$
- (3) Calculate W_{a1} , W_{a2} and W_{a3} and
- (4) Determine MABL = the largest of W_{a1} , W_{a2} and W_{a3}

Appendix (contd)

PVRC Method Notations

The notations below are used in the formulas for the PVRC method of flange design:

A_b = Total actual cross-sectional area of stud bolts based on the least diameter of the stud under stress, usually at the root diameter of the thread, in².

A_g = Gasket contact area, based on the contact width, $n_o = 0.7854(OD^2 - ID^2)$ or $= 3.14 (G_o - n_o) n_o$, in².

A_i = Pressurized (hydraulic) area, encircled by the effective diameter, G .
 $= 0.7854 \times G^2$, in².

A_m = Total required cross-sectional area of bolts based on the least diameter of the stud under stress, usually at the root diameter of the thread.

A_m = W_{mo}/S_b , in².

A_p = Partition gasket contact area, in².

a = Exponent of gasket assembly-loading curve (slope on a log-log plot) used to calculate gasket stress, S_{ya} , a gasket constant, and a gasket property.

FA = Applied axial force, lbs, due to externally applied mechanical loads and flange misalignment. FA is positive when the force tends to part the flanges, otherwise zero.

G = Effective gasket diameter that locates the gasket load reaction. Used to calculate the pressurized area, A_i .

G_b = Gasket property used to describe the assembly-loading curve. Also a gasket constant, psi (MPa). G_b equals gasket stress at $T_p = 1$. G_b together with a is used to calculate S_{ya} .

G_c = Outside diameter of gasket contact, in, representing the smaller of the Gasket OD or flange contact surface OD.

G_s = Gasket property used to describe the unloading curve. G_s equals gasket operating stress at $T_p = 1$. G_s is used

with k to calculate S_{m1} and is associated with maintaining the required minimum tightness after the application of fluid pressure and other loads.

k = Exponent of the gasket unloading curve (slope on a log-log plot) used to calculate S_{m1} .

M_E = Absolute value of externally applied bending moments. Includes those due to misalignment, in-lbs.

N = Gasket contact width, in.

n_o = Basic gasket width, in., the same as N except for nubbin facings and RTJ type gaskets

n = Effective gasket width defining G , in.

P = Internal design pressure, psi.

P_t = Test pressure, psi.

Q = A factor that varies between 0 and 1.0 that adjusts the overall effect of non-uniform gasket stress caused by external bending moment to an equivalent axial load. $Q = 1.0$ is normally used.

S_a = Allowable bolt stress at atmospheric temperature, psi.

S_b = Allowable bolt stress at design temperature, psi.

S_c = Maximum permissible gasket stress to avoid tightness performance damage.

S_l = The minimum permitted value of S_{mo} stress in the test that determined the gasket constants. S_l is 900 psi for most gaskets and 1500 psi for solid metal gaskets.

S_{m1} = Minimum gasket stress to meet the required joint tightness, T_{pmin}

S_{mo} = Design gasket stress, psi = The largest of S_{m1} , S_{m3} , $2P/\eta$, or S_l/η , psi.

Appendix (contd)

- S_{m2} = Design operating gasket stress after application of pressure and external loads.
- S_{m3} = Average operating gasket stress after application of pressure and external loads.
- S_s = Gasket stress developed when contact is initiated with a compression-limiting device, or stop, such as a groove containing the gasket, or a gage ring, or a stress associated with a tightness limit such as T_{pmax} .
- S_{ya} = Design gasket assembly stress used to calculate S_{m1} , S_{m2} , and S_{m3} , psi, and W_{a2} .
- T_c = Tightness class factor.
- T_p = Tightness Parameter expressing the ratio of pressure to the square root of leak rate in dimensionless form. It is based on mass leak rate. Leakage is assumed proportional to gasket diameter. T_p is the pressure (in atmospheres) required to cause a helium leak rate of 1 mg/sec for a 5.9" (150 mm) OD gasket in a joint.
- T_{pa} = Assembly tightness, value of T_p required to assure that T_{pmin} is achieved in operation.
- T_{pmax} = A gasket property obtained by test that determines the maximum use able assembly tightness.
- T_{pmin} = Minimum required tightness, value of T_p required to assure that satisfactory leakage performance is achieved in operation for the specified tightness class.
= $0.1243(T_c)P$ (P in psi)
- W_{mo} = Minimum required bolt load, lb.
- X = The ratio T_{pa}/T_{pmin} used in Formula (2).
- η = Assembly efficiency, also known as A_e , the ratio of minimum to average gasket stress, which accounts for variations in bolt load and its effect on gasket stress. It is assumed dependent on the method of joint assembly.
 $\eta = 1.00$ for "ideal" bolt-up such as for ultrasonics or direct stud stretch control; 0.95 for very good bolt-up such as for hydraulic tensioners; 0.85 for well-controlled bolt-up such as by torque wrench; 0.75 for manual bolt-up or air impact.

PVRC Flow Chart

This chart represents the calculation process to determine design load for flange connection.

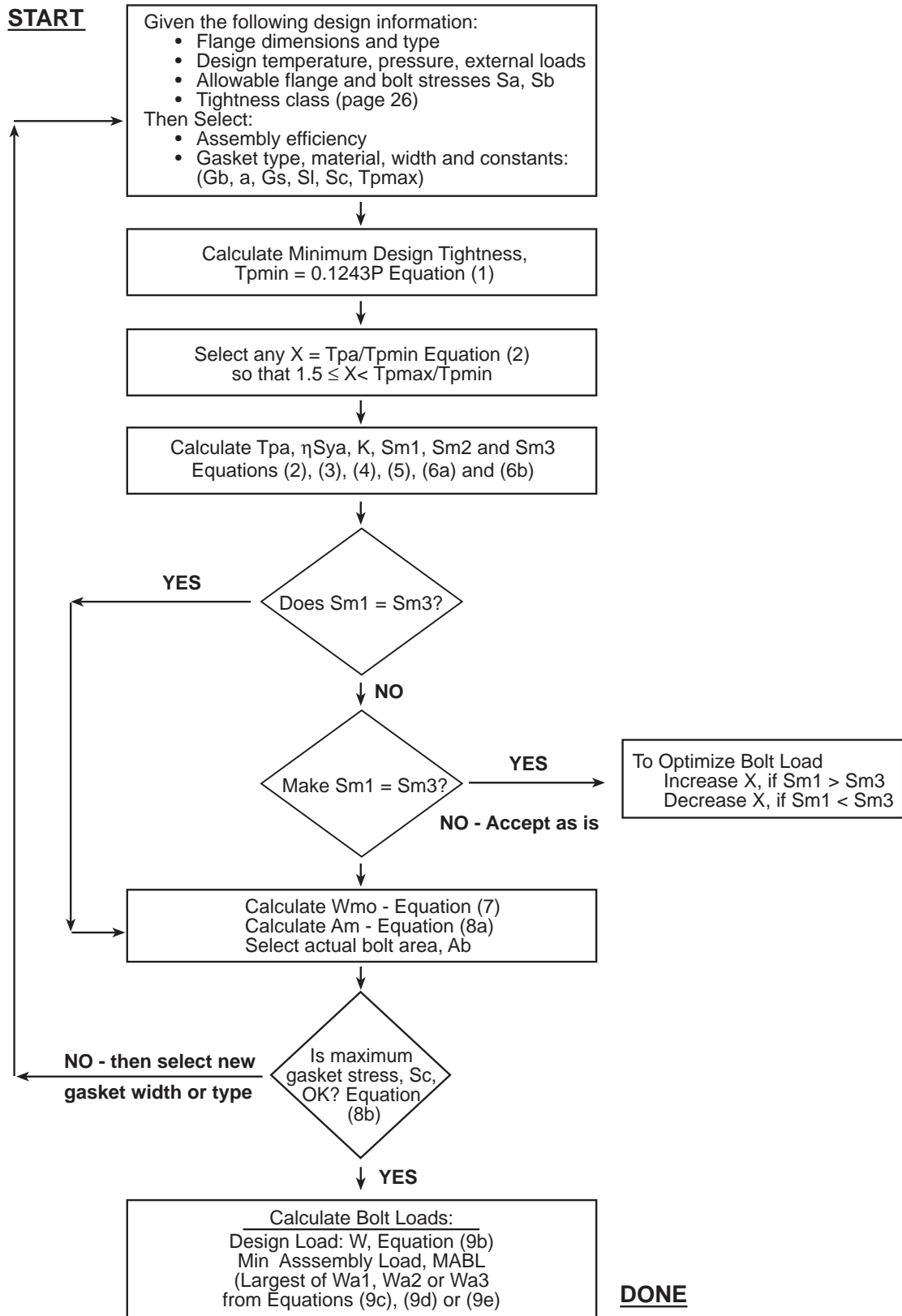

Gasket Dimensions for Standard Flanges

GRAPHONIC® Series of Gaskets for ASME/ANSI B16.5 flanges to ANSI B 16.21-1992

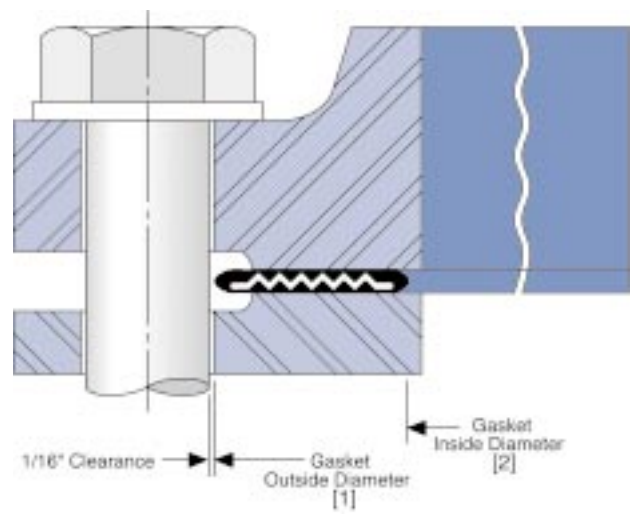

Nominal Pipe Size (inches)	Gasket Contact Width (inches)	Gasket Inside Diameter [2]	Gasket Outside Diameter [1] Flange Pressure Rating Class (lb)					
			Class 150	Class 300	Class 400	Class 600	Class 900	Class 1500
1/2	0.27	27/32	1-7/8	—	—	2-1/8	—	2-1/2
3/4	0.31	1-1/16	2-1/4	—	—	2-5/8	—	2-3/4
1	0.34	1-5/16	2-5/8	—	—	2-7/8	—	3-1/8
1-1/4	0.42	1-21/32	3	—	—	3-1/4	—	3-1/2
1-1/2	0.48	1-29/32	3-3/8	—	—	3-3/4	—	3-7/8
2	0.62	2-3/8	4-1/8	—	—	4-3/8	—	5-5/8
2-1/2	0.62	2-7/8	4-7/8	—	—	5-1/8	—	6-1/2
3	0.75	3-1/2	5-3/8	—	—	5-7/8	6-5/8	6-7/8
3-1/2	0.75	4	6-3/8	6-1/2	—	6-3/8	—	—
4	0.84	4-1/2	6-7/8	7-1/8	7	7-5/8	8-1/8	8-1/4
5	0.88	5-9/16	7-3/4	8-1/2	8-3/8	9-1/2	9-3/4	10
6	0.94	6-5/8	8-3/4	9-7/8	9-3/4	10-1/2	11-3/8	11-1/8
8	1.00	8-5/8	11	12-1/8	12	12-5/8	14-1/8	13-7/8
10	1.00	10-3/4	13-3/8	14-1/4	14-1/8	15-3/4	17-1/8	17-1/8
12	1.12	12-3/4	16-1/8	16-5/8	16-1/2	18	19-5/8	20-1/2
14	1.12	14	17-3/4	19-1/8	19	19-3/8	20-1/2	22-3/4
16	1.25	16	20-1/4	21-1/4	21-1/8	22-1/4	22-5/8	25-1/4
18	1.50	18	21-5/8	23-1/2	23-3/8	24-1/8	25-1/8	27-3/4
20	1.50	20	23-7/8	25-3/4	25-1/2	26-7/8	27-1/2	29-3/4
24	1.62	24	28-1/4	30-1/2	30-1/4	31-1/8	33	35-1/2

Heat Exchanger Gaskets

Locations of Heat Exchanger Gaskets

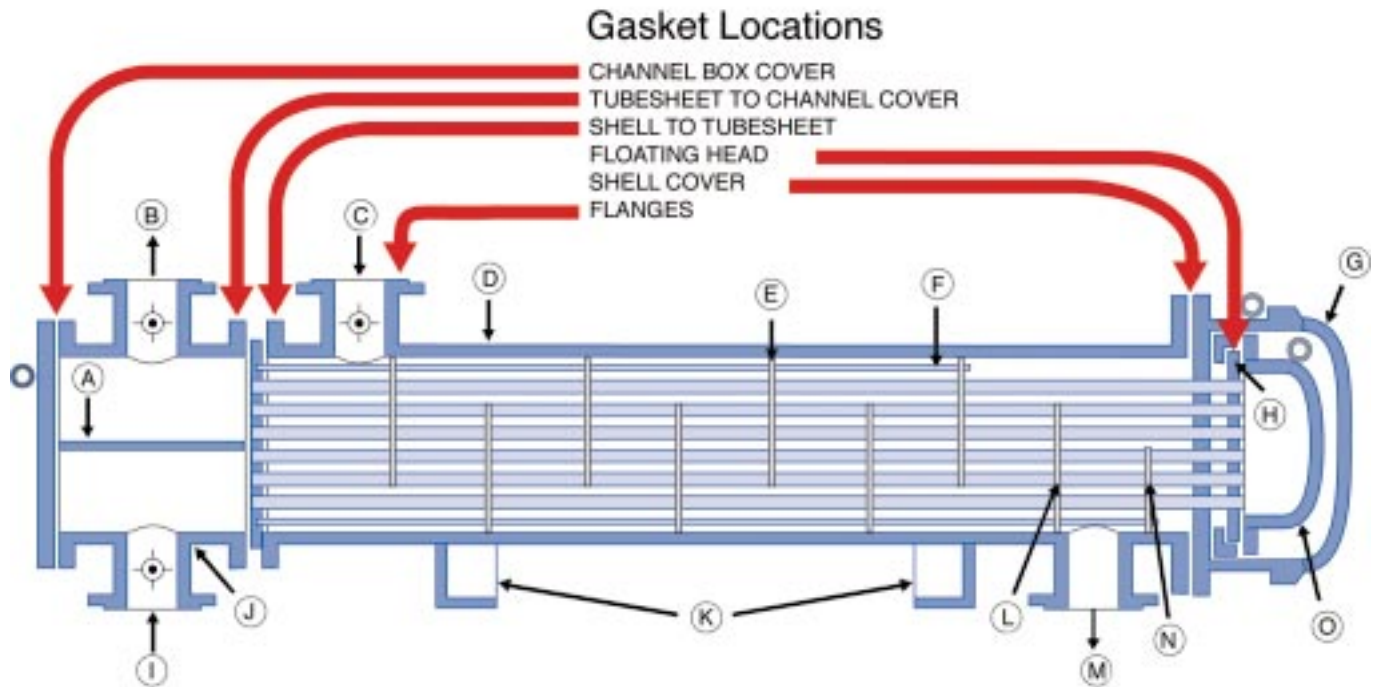

- | | |
|--------------------------|---------------------------------|
| (A) Pass partition | (I) Tubeside fluid in |
| (B) Tubeside fluid out | (J) Stationary-head channel |
| (C) Shell inlet | (K) Support saddles |
| (D) Shell | (L) Last baffle |
| (E) Baffles | (M) Shell outlet |
| (F) Tie rods and spacers | (N) Floating-head support plate |
| (G) Shell cover | (O) Floating-head cover |
| (H) Floating tubesheet | |

Heat Exchanger Gasket Shapes

Heat exchanger gaskets have complicated partition bar(s). The typical shapes of the Heat Exchanger

gaskets are illustrated below.

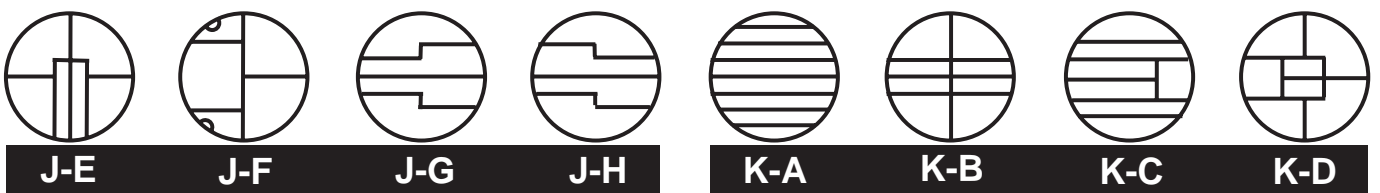
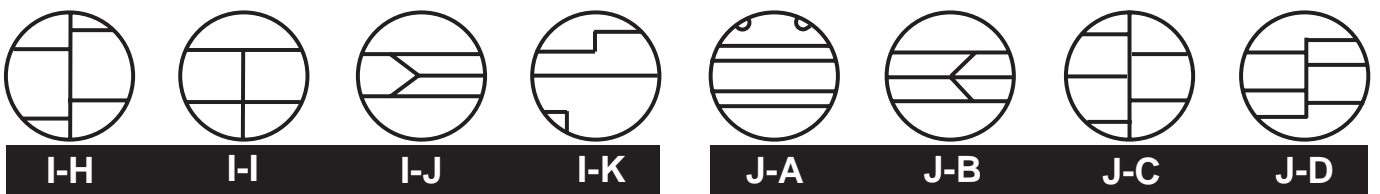
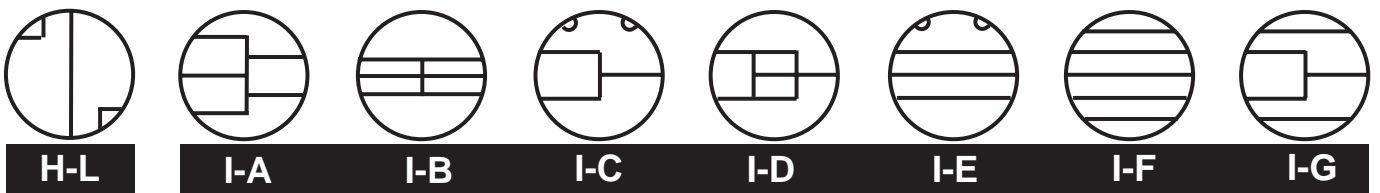
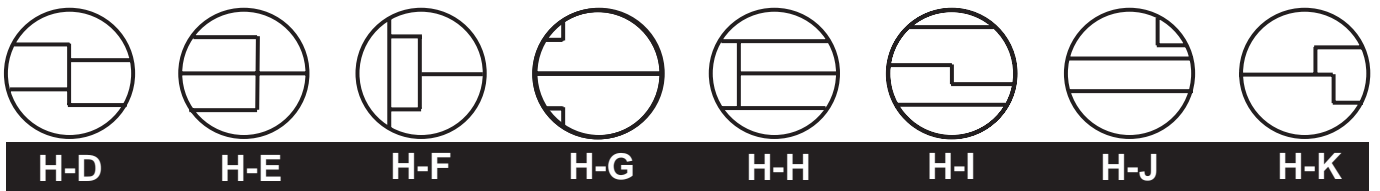
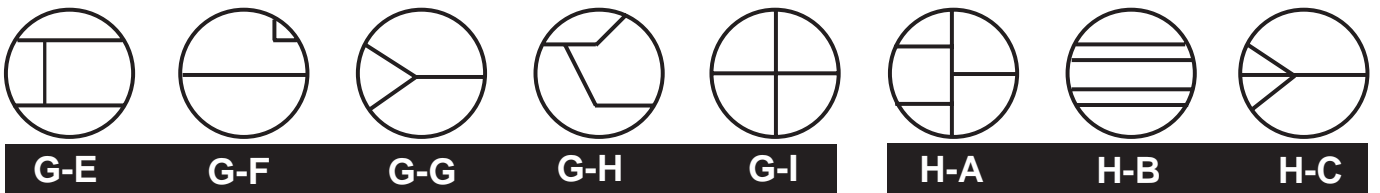
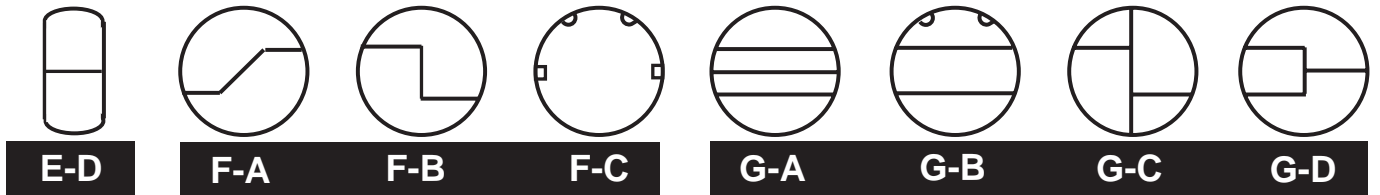
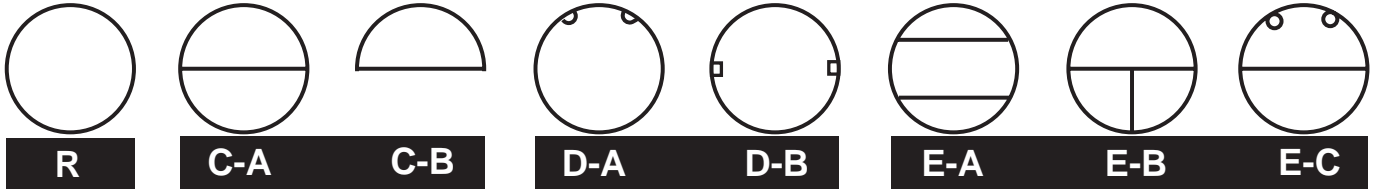

Bolt Torque Tables

GRAPHONIC® 150#

Nom Pipe Size (in.)	Gskt ID Contact (in.)	Gasket OD Contact (in.)	Gasket Area Contact (sq. in.)	No of Bolts	Size of Bolts (in.)	Max TQ per Bolt @ 60 Ksi Bolt Stress	Comp Force per Bolt @ 60 Ksi (ft-lb)	Max Gskt Comp. Avail (psi)	Min Gskt Comp. Rec (psi)	Min TQ Per Bolt (ft-lb)	Max Gskt Comp/Rec Avail (psi)	Preferred TQ (ft-lb)
0.5	0.84	1.38	0.93	4	0.50	60	7560	32491	6000	11	30000	55
0.75	1.06	1.69	1.35	4	0.50	60	7560	22333	6000	16	22333	60
1	1.31	2.00	1.79	4	0.50	60	7560	16858	6000	21	16858	60
1.25	1.66	2.50	2.74	4	0.50	60	7560	11018	6000	33	11018	60
1.5	1.91	2.88	3.63	4	0.50	60	7560	8338	6000	43	8338	60
2	2.38	3.63	5.87	4	0.63	120	12120	8256	6000	87	8256	120
2.5	2.88	4.13	6.85	4	0.63	120	12120	7078	6000	102	7078	120
3	3.50	5.00	10.01	4	0.63	120	12120	4841	4841	120	4841	120
4	4.50	6.19	14.16	8	0.63	120	12120	6845	6000	105	6845	120
5	5.56	7.31	17.72	8	0.75	200	18120	8182	6000	147	8182	200
6	6.62	8.50	22.33	8	0.75	200	18120	6493	6000	185	6493	200
8	8.62	10.63	30.31	8	0.75	200	18120	4783	4783	200	4783	200
10	10.75	12.75	36.91	12	0.88	320	25140	8173	6000	235	8173	320
12	12.75	15.00	49.04	12	0.88	320	25140	6152	6000	312	6152	320
14	14.00	16.25	53.46	12	1.00	490	33060	7421	6000	396	7421	490
16	16.00	18.50	67.74	16	1.00	490	33060	7809	6000	377	7809	490
18	18.00	21.00	91.89	16	1.13	710	43680	7605	6000	560	7605	710
20	20.00	23.00	101.32	20	1.13	710	43680	8622	6000	494	8622	710
24	24.00	27.25	130.82	20	1.25	1000	55740	8522	6000	704	8522	1000

GRAPHONIC® 300#

Nom Pipe Size (in.)	Gskt ID Contact (in.)	Gasket OD Contact (in.)	Gasket Area Contact (sq. in.)	No of Bolts	Size of Bolts (in.)	Max TQ per Bolt @ 60 Ksi Bolt Stress	Comp Force per Bolt @ 60 Ksi (ft-lb)	Max Gskt Comp. Avail (psi)	Min Gskt Comp. Rec (psi)	Min TQ Per Bolt (ft-lb)	Max Gskt Comp/Rec Avail (psi)	Preferred TQ (ft-lb)
0.5	0.84	1.38	0.93	4	0.50	60	7560	32491	6000	11	30000	55
0.75	1.06	1.69	1.35	4	0.63	120	12120	35803	6000	20	30000	101
1	1.31	2.00	1.79	4	0.63	120	12120	27027	6000	27	27027	120
1.25	1.66	2.50	2.74	4	0.63	120	12120	17664	6000	41	17664	120
1.5	1.91	2.88	3.63	4	0.75	200	18120	19986	6000	60	19986	200
2	2.38	3.63	5.87	8	0.63	120	12120	16513	6000	44	16513	120
2.5	2.88	4.13	6.85	8	0.75	200	18120	21163	6000	57	21163	200
3	3.50	5.00	10.01	8	0.75	200	18120	14476	6000	83	14476	200
4	4.50	6.19	14.16	8	0.75	200	18120	10234	6000	117	10234	200
5	5.56	7.31	17.72	8	0.75	200	18120	8182	6000	147	8182	200
6	6.62	8.50	22.33	12	0.75	200	18120	9740	6000	123	9740	200
8	8.62	10.63	30.31	12	0.88	320	25140	9955	6000	193	9955	320
10	10.75	12.75	36.91	16	1.00	490	33060	14330	6000	205	14330	490
12	12.75	15.00	49.04	16	1.13	710	43680	14252	6000	299	14252	710
14	14.00	16.25	53.46	20	1.13	710	43680	16342	6000	261	16342	710
16	16.00	18.50	67.74	20	1.25	1000	55740	16457	6000	365	16457	1000
18	18.00	21.00	91.89	24	1.25	1000	55740	14558	6000	412	14558	1000
20	20.00	23.00	101.32	24	1.25	1000	55740	13204	6000	454	13204	1000
24	24.00	27.25	130.82	24	1.50	1600	84300	15466	6000	621	15466	1600

Application Data Form

Date _____

For: Garlock Metallic Gasketing Engineering

Fax 1-281-458-0502

Page: 1 of _____

Drawing attached Yes No

From _____

Title _____

Company _____

Address _____

Fax No. _____

Phone No. _____

E-mail Address _____

Application

Pipe Flange

Heat Exchanger

Manway

Compressor

Pumps – centrifugal / horizontal split case

Flue Duct

Valve Bonnet

Other _____

Service Conditions

Maximum Temperature _____ °F / °C

Continuous Operating Temperature _____ °F / °C

Internal Pressure _____ psig / bar

PSIG / bar

Continuous

Intermittent

Thermal Cycling _____ / 24 hours

Vibration

Yes

No

Other (specify) _____

Bolts

Grade _____

Diameter _____

Length _____

Number _____

Chemical Compatibility

Media _____

pH _____

Concentration _____

Liquid or Gas _____

Flange

Standard

Material _____

Size _____ Rating _____

Surface Finish _____ RMS

Phonographic

Concentric

Face (raised, flat, tongue & groove, etc.)

Non-Standard

Material _____

I.D. / O.D. _____

Flange Thickness _____

Bolt Circle Diameter _____

Surface Finish _____ RMS

Phonographic Concentric

Face (raised, flat, tongue & groove, etc.) _____

Comments: _____

AUTHORIZED DISTRIBUTOR

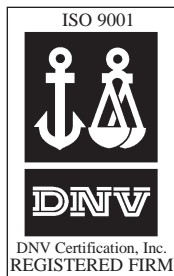
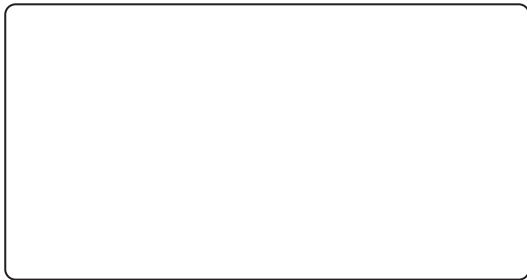

WARNING:

Properties/applications shown throughout this brochure are typical. Your specific application should not be under taken without independent study and evaluation for suitability. For specific application recommendations consult Garlock. Failure to select the proper sealing products could result in property damage and/or serious personal injury.

Performance data published in this brochure has been developed from field testing, customer field reports and/or in-house testing.

While the utmost care has been used in compiling this brochure, we assume no responsibility for errors. Specifications subject to change without notice. This edition cancels all previous issues. Subject to change without notice.

GARLOCK is a registered trademark for packings, seals, gaskets, and other products of Garlock.

© Garlock Inc 2001. All rights reserved worldwide.

GOODRICH

Garlock Sealing Technologies
Metallic Gaskets
1977 Kindred Street
Houston, TX 77049 USA
1-281-459-7200
Fax: 1-281-458-0502

Visit the Garlock network
www.garlock.net

Other Garlock facilities are located in:

Palmyra, NY, USA	1-800-448-6688	Fax: 1-315-597-3216
Paragould, AR, USA	1-870-239-4051	Fax: 1-870-239-4054
Columbia, SC, USA	1-803-783-1880	Fax: 1-803-783-4279
Sydney, Australia	61-2-9793-2511	Fax: 61-2-9793-2544
São Paulo, Brazil	55-11-884-9680	Fax: 55-11-884-9680
Oakville, Canada	1-905-829-3200	Fax: 1-905-829-3333
Berkshire, England	44-1635-38509	Fax: 44-1635-569573
Saint-Étienne, France	33-4-7743-5100	Fax: 33-4-7743-5151
Neuss, Germany	49-2131-3490	Fax: 49-2131-349-222
Seoul, Korea	822-554-6341	Fax: 822-554-6343
Mexico City, Mexico	52-5-567-7011	Fax: 52-5-368-0418
Singapore	65-254-7372	Fax: 65-254-6708